

ETSI EN 300 392-3-1 V1.4.1 (2015-12)



EUROPEAN STANDARD

**Terrestrial Trunked Radio (TETRA);
Voice plus Data (V+D);
Part 3: Interworking at the Inter-System Interface (ISI);
Sub-part 1: General design**

Reference

REN/TCCE-03236

Keywords

interworking, radio, TETRA, V+D

ETSI

650 Route des Lucioles
F-06921 Sophia Antipolis Cedex - FRANCE

Tel.: +33 4 92 94 42 00 Fax: +33 4 93 65 47 16

Siret N° 348 623 562 00017 - NAF 742 C
Association à but non lucratif enregistrée à la
Sous-Préfecture de Grasse (06) N° 7803/88

Important notice

The present document can be downloaded from:
<http://www.etsi.org/standards-search>

The present document may be made available in electronic versions and/or in print. The content of any electronic and/or print versions of the present document shall not be modified without the prior written authorization of ETSI. In case of any existing or perceived difference in contents between such versions and/or in print, the only prevailing document is the print of the Portable Document Format (PDF) version kept on a specific network drive within ETSI Secretariat.

Users of the present document should be aware that the document may be subject to revision or change of status. Information on the current status of this and other ETSI documents is available at
<http://portal.etsi.org/tb/status/status.asp>

If you find errors in the present document, please send your comment to one of the following services:
<https://portal.etsi.org/People/CommitteeSupportStaff.aspx>

Copyright Notification

No part may be reproduced or utilized in any form or by any means, electronic or mechanical, including photocopying and microfilm except as authorized by written permission of ETSI.

The content of the PDF version shall not be modified without the written authorization of ETSI.
The copyright and the foregoing restriction extend to reproduction in all media.

© European Telecommunications Standards Institute 2015.
All rights reserved.

DECT™, **PLUGTESTS™**, **UMTS™** and the ETSI logo are Trade Marks of ETSI registered for the benefit of its Members.
3GPP™ and **LTE™** are Trade Marks of ETSI registered for the benefit of its Members and of the 3GPP Organizational Partners.
GSM® and the GSM logo are Trade Marks registered and owned by the GSM Association.

Contents

Intellectual Property Rights	5
Foreword.....	5
Modal verbs terminology.....	6
1 Scope	7
2 References	7
2.1 Normative references	7
2.2 Informative references.....	8
3 Definitions and abbreviations.....	9
3.1 Definitions.....	9
3.2 Abbreviations	10
4 ISI standardization methodology.....	11
4.1 3 stage methodology.....	11
4.1.0 General.....	11
4.1.1 Stage 1 description.....	11
4.1.2 Stage 2 description.....	12
4.1.3 Stage 3 description.....	12
4.2 Usage of Specification and Description Language (SDL).....	12
5 Usage of Private Signalling System 1 (PSS1) for TETRA	13
5.1 PSS1 functionality.....	13
5.2 Protocol stack for signalling information	13
5.3 Generic Functional Protocol (GFP).....	14
5.4 Protocol stack for user information	15
6 TETRA SwMI roles using ISI.....	15
6.1 Management configurations	15
6.1.1 Migration and group attachment configurations.....	15
6.1.1.1 SwMI roles for migration and group attachment	15
6.1.1.2 SwMI databases	16
6.1.1.3 Migration scenarios.....	17
6.1.1.4 Group attachment scenarios	18
6.1.2 Group linking configurations.....	18
6.2 Call configurations	20
6.2.0 General.....	20
6.2.1 Group call configuration.....	20
6.2.2 Individual call configuration.....	22
6.2.3 Transit.....	23
6.3 User information encoding at the ISI	23
7 Introduction to ISI ANFs.....	23
7.0 General	23
7.1 ANF-ISIMM.....	24
7.2 ANF-ISIIC.....	24
7.3 ANF-ISIGC	24
7.4 ANF-ISISDS	24
7.5 ANF-ISISS	24
8 ISI Generic Functional Protocol (ISI GFP)	24
8.1 Protocol model	24
8.2 Services provided by the protocol model entities.....	25
8.3 Addressing and transport.....	26
8.3.1 Addressing	26
8.3.2 Transport of ROSE APDUs.....	27
8.3.2.0 General	27
8.3.2.1 Call related ROSE APDUs.....	27
8.3.2.2 Call unrelated ROSE APDUs.....	27

8.3.2.2.0	General	27
8.3.2.2.1	Protocol for the establishment of a call independent signalling connection	27
8.3.2.2.2	Use of a call independent signalling connection already established	28
8.3.2.2.3	Clearing of a call independent signalling connection	28
8.4	Remote Operations Service Entity (ROSE) requirements and operation definition	29
8.4.1	General	29
8.4.2	Return-result	32
8.4.3	Return-error	32
8.4.4	Reject	33
8.5	Segmentation Service Element (SSE)	33
8.5.0	Overview	33
8.5.1	Procedures	34
8.5.1.0	General	34
8.5.1.1	Requirements for the segmentation procedure	34
8.5.1.2	Requirements for the re-assembly procedure	34
8.5.2	Segment encoding	35
8.6	Co-ordination Function	36
9	Security over the ISI	36
9.0	General	36
9.1	ITSI authentication	37
9.2	End-to-end encryption	37
9.3	End-to-end key management via ISI	37
Annex A (normative): Security - supporting encryption over ISI		38
A.1	Overview	38
A.2	Encryption	39
A.2.1	ISI relation to air interface and end-to-end encryption	39
A.2.2	Air interface encryption key management via ISI	39
A.2.2.0	General	39
A.2.2.1	Secret Key of individual subscriber (K)	40
A.2.2.2	Derived Cipher Key (DCK)	40
A.2.2.3	Common Cipher Key (CCK)	40
A.2.2.4	Static Cipher Key (SCK)	40
A.2.2.5	Group Cipher Key (GCK)	40
Annex B (informative): Maximum length of a ROSE APDU or a SSE segment encoded in a facility information element		41
B.0	General	41
B.1	PSS1 FACILITY message	41
B.2	PSS1 basic call message	42
B.3	Example of the encoding of an ANF-ISIMM MIGRATION PDU in a ROSE Invoke ROSE APDU in a call PISN FACILITY PDU	43
Annex C (informative): Change requests		45
History		46

Intellectual Property Rights

IPRs essential or potentially essential to the present document may have been declared to ETSI. The information pertaining to these essential IPRs, if any, is publicly available for **ETSI members and non-members**, and can be found in ETSI SR 000 314: *"Intellectual Property Rights (IPRs); Essential, or potentially Essential, IPRs notified to ETSI in respect of ETSI standards"*, which is available from the ETSI Secretariat. Latest updates are available on the ETSI Web server (<http://ipr.etsi.org>).

Pursuant to the ETSI IPR Policy, no investigation, including IPR searches, has been carried out by ETSI. No guarantee can be given as to the existence of other IPRs not referenced in ETSI SR 000 314 (or the updates on the ETSI Web server) which are, or may be, or may become, essential to the present document.

Foreword

This European Standard (EN) has been produced by ETSI Technical Committee TETRA and Critical Communications Evolution (TCCE).

The present document is part 3, sub-part 1 of a multi-part deliverable covering the Terrestrial Trunked Radio (TETRA); Voice plus Data (V+D), Release 2 as identified below:

ETSI EN 300 392-1: "General network design";

ETSI EN 300 392-2: "Air Interface (AI)";

ETSI EN 300 392-3: "Interworking at the Inter-System Interface (ISI)";

ETSI EN 300 392-3-1: "General design";

ETSI EN 300 392-3-2: "Additional Network Feature Individual Call (ANF-ISIIC)";

ETSI EN 300 392-3-3: "Additional Network Feature Group Call (ANF-ISIGC)";

ETSI EN 300 392-3-4: "Additional Network Feature Short Data Service (ANF-ISISDS)";

ETSI EN 300 392-3-5: "Additional Network Feature for Mobility Management (ANF-ISIMM)";

ETSI TS 100 392-3-6: "Speech format implementation for circuit mode transmission";

ETSI TS 100 392-3-7: "Speech Format Implementation for Packet Mode Transmission";

ETSI TS 100 392-3-8: "Generic Speech Format Implementation";

ETSI ETS 300 392-4: "Gateways basic operation";

ETSI EN 300 392-5: "Peripheral Equipment Interface (PEI)";

ETSI EN 300 392-7: "Security";

ETSI EN 300 392-9: "General requirements for supplementary services";

ETSI EN 300 392-10: "Supplementary services stage 1";

ETSI EN 300 392-11: "Supplementary services stage 2";

ETSI EN 300 392-12: "Supplementary services stage 3";

ETSI ETS 300 392-13: "SDL model of the Air Interface (AI)";

ETSI ETS 300 392-14: "Protocol Implementation Conformance Statement (PICS) proforma specification";

ETSI TS 100 392-15: "TETRA frequency bands, duplex spacings and channel numbering";

ETSI TS 100 392-16: "Network Performance Metrics";

ETSI TR 100 392-17: "TETRA V+D and DMO specifications";

ETSI TS 100 392-18: "Air interface optimized applications".

NOTE 1: Part 3, sub-parts 6 and 7 (Speech format implementation), part 4, sub-part 3 (Data networks gateway), part 10, sub-part 15 (Transfer of control), part 13 (SDL) and part 14 (PICS) of this multi-part deliverable are in status "historical" and are not maintained.

NOTE 2: Some parts are also published as Technical Specifications such as TS 100 392-2 and those may be the latest version of the document.

National transposition dates	
Date of adoption of this EN:	7 December 2015
Date of latest announcement of this EN (doa):	31 March 2016
Date of latest publication of new National Standard or endorsement of this EN (dop/e):	30 September 2016
Date of withdrawal of any conflicting National Standard (dow):	30 September 2016

Modal verbs terminology

In the present document "**shall**", "**shall not**", "**should**", "**should not**", "**may**", "**need not**", "**will**", "**will not**", "**can**" and "**cannot**" are to be interpreted as described in clause 3.2 of the [ETSI Drafting Rules](#) (Verbal forms for the expression of provisions).

"**must**" and "**must not**" are **NOT** allowed in ETSI deliverables except when used in direct citation.

1 Scope

The present document defines the general aspects of interworking at the Inter-System Interface (ISI) for Terrestrial Trunked Radio (TETRA) system supporting Voice plus Data (V+D). Those specify the general concepts which are the basis of the ISI operation between TETRA systems. It introduces the Additional Network Features (ANFs) used at the ISI, and specifies:

- the general protocol mechanism, called ISI Generic Functional Protocol (ISI GFP), upon which the definition of each ANF is based; and
- the security requirements for the ISI.

The ISI GFP specification applies to any TETRA Switching and Management Infrastructure (SwMI) which supports the ISI. The security requirements for the ISI only apply to SwMIs which support authentication or encryption over the ISI.

Besides the ISI general design, the present document, interworking at the Inter-System Interface comprises the following other sub-parts:

- Additional Network Feature - ISI Individual Call (ANF-ISIIC);
- Additional Network Feature - ISI Group Call (ANF-ISIGC);
- Additional Network Feature - ISI Short Data service (ANF-ISISDS); and
- Additional Network Feature - ISI Mobility Management (ANF-ISIMM).

2 References

2.1 Normative references

References are either specific (identified by date of publication and/or edition number or version number) or non-specific. For specific references, only the cited version applies. For non-specific references, the latest version of the reference document (including any amendments) applies.

Referenced documents which are not found to be publicly available in the expected location might be found at <http://docbox.etsi.org/Reference>.

NOTE: While any hyperlinks included in this clause were valid at the time of publication, ETSI cannot guarantee their long term validity.

The following referenced documents are necessary for the application of the present document.

- [1] ETSI EN 300 392-1: "Terrestrial Trunked Radio (TETRA); Voice plus Data (V+D); Part 1: General network design".
- [2] ETSI EN 300 392-2: "Terrestrial Trunked Radio (TETRA); Voice plus Data (V+D); Part 2: Air Interface (AI)".
- [3] ETSI EN 300 392-3-2: "Terrestrial Trunked Radio (TETRA); Voice plus Data (V+D); Part 3: Interworking at the Inter-System Interface (ISI); Sub-part 2: Additional Network Feature Individual Call (ANF-ISIIC)".
- [4] ETSI EN 300 392-3-3: "Terrestrial Trunked Radio (TETRA); Voice plus Data (V+D); Part 3: Interworking at the Inter-System Interface (ISI); Sub-part 3: Additional Network Feature Group Call (ANF-ISIGC)".
- [5] ETSI EN 300 392-3-4: "Terrestrial Trunked Radio (TETRA); Voice plus Data (V+D); Part 3: Interworking at the Inter-System Interface (ISI); Sub-part 4: Additional Network Feature Short Data Service (ANF-ISISDS)".
- [6] ETSI EN 300 392-3-5: "Terrestrial Trunked Radio (TETRA); Voice plus Data (V+D); Part 3: Interworking at the Inter-System Interface (ISI); Sub-part 5: Additional Network Feature for Mobility Management (ANF-ISIMM)".

- [7] ETSI TS 100 392-3-8: "Terrestrial Trunked Radio (TETRA); Voice plus Data (V+D); Part 3: Interworking at the Inter-System Interface (ISI); Sub-part 8: Generic Speech Format Implementation".
- [8] ETSI EN 300 392-7: "Terrestrial Trunked Radio (TETRA); Voice plus Data (V+D); Part 7: Security".
- [9] ETSI EN 300 392-9: "Terrestrial Trunked Radio (TETRA); Voice plus Data (V+D); Part 9: General requirements for supplementary services".
- [10] ETSI ETS 300 402-1: "Integrated Services Digital Network (ISDN); Digital Subscriber Signalling System No. one (DSS1) protocol; Data link layer; Part 1: General aspects [ITU-T Recommendation Q.920 (1993), modified]".
- [11] ETSI ETS 300 402-2: "Integrated Services Digital Network (ISDN); Digital Subscriber Signalling System No. one (DSS1) protocol; Data link layer; Part 2: General protocol specification [ITU-T Recommendation Q.921 (1993), modified]".
- [12] ISO/IEC 11572: "Information technology -- Telecommunications and information exchange between systems -- Private Integrated Services Network -- Circuit mode bearer services -- Inter-exchange signalling procedures and protocol".
- [13] ISO/IEC 11582: "Information technology -- Telecommunications and information exchange between systems -- Private Integrated Services Network -- Generic functional protocol for the support of supplementary services -- Inter-exchange signalling procedures and protocol".
- [14] Recommendation ITU-T G.704: "Synchronous frame structures used at 1544, 6312, 2048, 8448 and 44 736 kbit/s hierarchical levels".
- [15] Recommendation ITU-T Q.931: "ISDN user-network interface layer 3 specification for basic call control".
- [16] Recommendation ITU-T X.690: "Information technology - ASN.1 encoding rules: Specification of Basic Encoding Rules (BER), Canonical Encoding Rules (CER) and Distinguished Encoding Rules (DER)".
- [17] Recommendation ITU-T X.219: "Remote Operations: Model, notation and service definition".
- [18] Recommendation ITU-T X.882: "Information technology - Remote Operations: OSI realizations - Remote Operations Service Element (ROSE) protocol specification Remote Operations: Protocol specification".

2.2 Informative references

References are either specific (identified by date of publication and/or edition number or version number) or non-specific. For specific references, only the cited version applies. For non-specific references, the latest version of the reference document (including any amendments) applies.

NOTE: While any hyperlinks included in this clause were valid at the time of publication, ETSI cannot guarantee their long term validity.

The following referenced documents are not necessary for the application of the present document but they assist the user with regard to a particular subject area.

- [i.1] ETSI EN 300 395-1: "Terrestrial Trunked Radio (TETRA); Speech CODEC for full-rate traffic channel; Part 1: General description of speech functions".
- [i.2] Recommendation ITU-T I.130: "Method for the characterization of telecommunication services supported by an ISDN and network capabilities of an ISDN".
- [i.3] Recommendation ITU-T Z.100: "Specification and description language (SDL)".
- [i.4] Recommendation ITU-T E.164: "The international public telecommunication numbering plan".

3 Definitions and abbreviations

3.1 Definitions

For the purposes of the present document, the terms and definitions given in ISO/IEC 11582 [13] and the following apply:

call independent: property of information which is conveyed across the Q reference point in a message that does not use a call reference which has an associated user-information connection

NOTE: In TETRA standards, the term call unrelated is used with the same meaning as call independent.

call independent signalling connection: signalling connection established between ANF-ISI entities located in different Switching and Management Infrastructures that does not have an associated user-information connection

call unrelated: See the definition of the term "call independent".

co-ordination Function: entity which provides co-ordination between different ANF-ISI entities, ROSE, SSE and GFT Control for different TETRA basic and supplementary services

destination SwMI: Switching and Management Infrastructure where the receiving ANF-ISI entity is located (in the context of a single one-way exchange of information between two ANF-ISI entities located in different Switching and Management Infrastructures)

Generic Functional Transport Control (GFT Control) entity: entity that exists within a Switching and Management Infrastructure and provides a range of services to the ANF-ISI entities and ROSE via the co-ordination Function

NOTE: The services are defined in clause 6 of ISO/IEC 11582 [13].

group attached SwMI: Switching and Management Infrastructure different from the home SwMI of the group considered in which at least one individual subscriber member of the group is attached to that group

Group TETRA Subscriber Identity (GTSI): TETRA Subscriber Identity assigned to a group

home SwMI: Switching and Management Infrastructure in which the subscription of a given user is registered

NOTE: That user is defined as being a subscriber (see below the definition of that term).

invocation: action taken by the user or by the service provider to execute a specific service function within real time

Location Area (LA): area within radio coverage of a base station or group of base stations within which a Mobile Station (MS) is allowed to operate

Mobile Network Identity (MNI): identity that is broadcast by all TETRA base stations to uniquely identify the SwMI

NOTE: It consists of the Mobile Country Code (MCC) and the Mobile Network Code (MNC).

Mobile Station (MS): physical grouping that contains all of the mobile equipment that is used to obtain TETRA services

NOTE: By definition, a mobile station contains at least one Mobile Radio Stack (MRS).

originating SwMI: in the context of a TETRA call, Switching and Management Infrastructure where the calling user is registered (which implies that this user is located in that SwMI) or Switching and Management Infrastructure which originates a Call independent signalling connection

segmentation: act of generating two or more PDUs derived from an initial one

service user: abstract representation of the totality of those entities in a single system that makes use of a service through a single access point

Short Subscriber Identity (SSI): network specific portion of a TSI

NOTE: A SSI is only unique within one TETRA sub-domain (one TETRA network).

source SwMI: Switching and Management Infrastructure where the sending ANF-ISI entity is located (in the context of a single one-way exchange of information between two ANF-ISI entities located in different Switching and Management Infrastructures)

subscriber: user of a telecommunication service, based on a contract with the provider of the service

NOTE 1: The subscriber may be an individual or a group: in the first case it is identified by an ITSI, in the second, by a GTSI.

NOTE 2: The individual subscriber is able to access an SwMI either through a MS or Line Station.

supplementary service: modifies or supplements a basic bearer service or a basic teleservice

NOTE: A supplementary service cannot be offered to a customer as a stand-alone service. It should be offered in combination with a bearer service or a teleservice.

Switching and Management Infrastructure (SwMI): all of the TETRA equipment for a Voice plus Data (V+D) network

NOTE: The SwMI enables users to communicate with each other.

terminating SwMI: in the context of a TETRA call, Switching and Management Infrastructure where the calling user is registered (which implies that this user is located in that SwMI) or Switching and Management Infrastructure which terminates a Call independent signalling connection

TETRA Subscriber Identity (TSI): global TETRA network address that is to identify an individual or a group subscriber within the domain of all TETRA networks

user: entity using the services of a telecommunications network via an externally accessible service access point

NOTE: An individual user may be a person or an application process.

visited SwMI: Switching and Management Infrastructure different from the home SwMI in which a given subscriber is currently registered

NOTE: The definition of this term implies that the given subscriber is mobile and has moved away from his home SwMI (to register in this visited SwMI). Therefore, it cannot apply to a group.

3.2 Abbreviations

For the purposes of the present document, the following abbreviations apply:

(V)ASSI	Visiting Alias Short Subscriber Identity
(V)GSSI	Visiting Group Short Subscriber Identity
AC	Authentication Centre
ANF	Additional Network Feature
ANF-ISI	Additional Network Features of the Inter-System Interface
APDU	Application Protocol Data Unit
ASN.1	Abstract Syntax Notation One
BER	Basic Encoding Rules
BS	Base Station
C	Conditional
CAD	Call Authorized by Dispatcher
CCK	Common Cipher Key
CF	Call Forwarding
C-LDB	Controlling Linking DataBase
DCK	Derived Cipher Key
E.1	E-carrier signal level 1, 2 048 kbit/s
ECMA	European Computer Manufacturers Association
GCK	Group Cipher Key
GFP	Generic Functional Protocol
GFT	Generic Functional Transport
G-HDB	Group Home DataBase
GTSI	Group TETRA Subscriber Identity
G-VDB	Group Visited DataBase

HAC	Home Authentication Centre
HDB	Home DataBase
HDLC	High-level Data Link Control
I-HDB	Individual Home DataBase
ISI	Inter-System Interface
ISSI	Individual Short Subscriber Identity
ITSI	Individual TETRA Subscriber Identity
I-VDB	Individual Visited DataBase
K	authentication Key
KS	Session Key
LA	Location Area
LAPD	Link Access Procedure for the D-Channel
LS	Line Station
M	Mandatory
MCC	Mobile Country Code
MM	Mobility Management
MNC	Mobile Network Code
MNI	Mobile Network Identity
MRS	Mobile Radio Stack
MS	Mobile Station
MSISDN	Mobile Station ISDN number
NFE	Network Facility Extension
O	Optional
OTAR	Over The Air Re-keying
PC	Protocol Control
PDU	Protocol Data Unit
PINX	Private Integrated Network eXchange
PISN	Private Integrated Services Network
PN	Party Number
PSS1	Private Signalling System 1
PSTN	Public Switched Telephone Network
QSIG	Q interface SIGnalling protocol
ROSE	Remote Operation Service Element
RS	Random Seed
SCK	Static Cipher Key
SDL	Specification and Description Language
SDS	Short Data Service
SS	Supplementary Services
SSE	Segmentation Service Element
SSI	Short Subscriber Identity
SwMI	TETRA Switching and Management Infrastructure
TSI	TETRA Subscriber Identity
V+D	Voice plus Data
VAC	Visitor Authentication Centre
VDB	Visitor DataBase

4 ISI standardization methodology

4.1 3 stage methodology

4.1.0 General

The ISI Additional Network Features (ANFs), listed in clause 7, are standardized using the modelling method defined in Recommendation ITU-T I.130 [i.2].

4.1.1 Stage 1 description

Stage 1 description defines the services which the standardized ANF entity provides to the concerned service users, e.g. SwMI entities in the case of TETRA. The services are visible at the Service Access Points (SAPs). The stage 1 description is intended to allow an understanding of the services independently from the implementation.

For normal point-to-point services the service model is shown in figure 1.

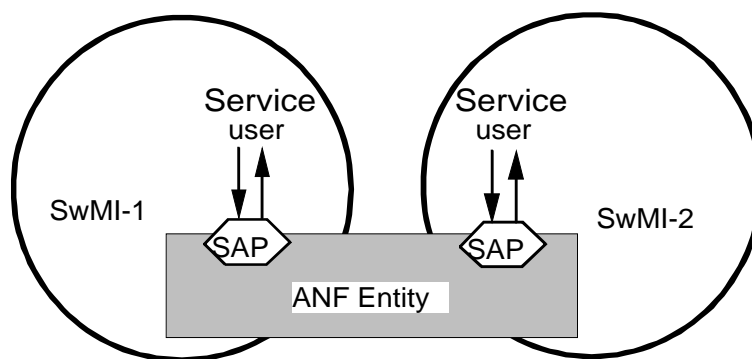

Figure 1: Service model for point-to-point services

For point-to-multipoint services the service model is shown in figure 2.

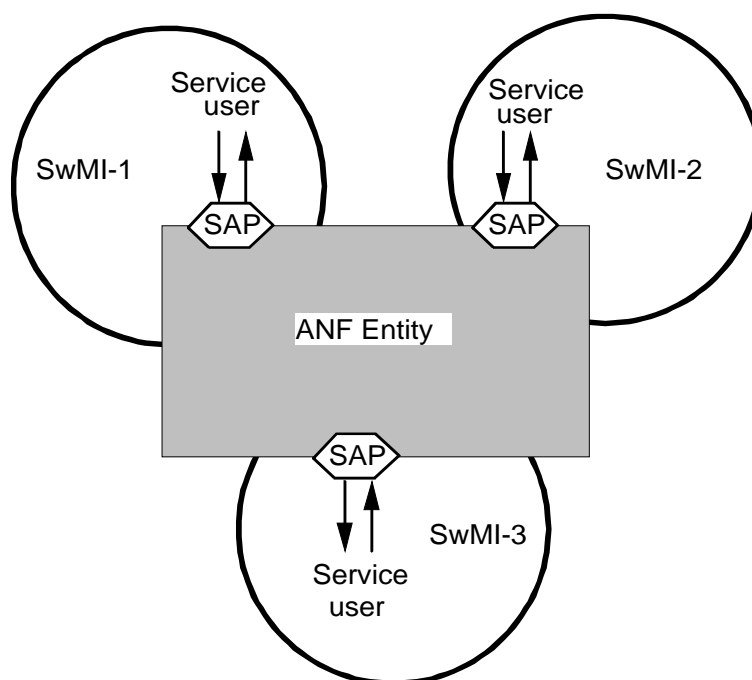

Figure 2: Service model for point-to-multipoint services

4.1.2 Stage 2 description

Stage 2 description identifies the functional capabilities and the information flows needed to support the service as described in stage 1.

4.1.3 Stage 3 description

Stage 3 description gives a precise specification of the signalling protocols for the ANF services, i.e. the encoding rules for the information flows and the corresponding procedures.

4.2 Usage of Specification and Description Language (SDL)

SDL defined in Recommendation ITU-T Z.100 [i.3] is used to identify and represent the behaviour of the concerned ANF in providing services.

5 Usage of Private Signalling System 1 (PSS1) for TETRA

5.1 PSS1 functionality

The TETRA ISI application is built on top of the PSS1 protocol stack for interconnecting Private Integrated services Network eXchanges (PINXs) to form Private Integrated Services Network (PISN). PSS1 is the ISO term; the PSS1 protocol is also known, informally, as QSIG, generic term created by the European Computer Manufacturers Association (ECMA) which developed most of the signalling protocols comprised in the PSS1 protocol.

TETRA uses the standard functionalities defined for PSS1:

- signalling for the support of circuit-mode basic services (see note);
- Generic Functional Protocol (GFP) originally defined for the support of supplementary services.

NOTE: The definition of PSS1 basic call in ISO/IEC 11572 [12] is as follows:

"The basic call is a single invocation of a basic service. Signalling procedures are used for establishing, maintaining and clearing a circuit-mode call at an interface between two PINXs. These signalling procedures are defined in terms of messages exchanged over a signalling carriage mechanism connection within the signalling channel of the Inter-PINX link. The result of successful basic call establishment is a connection for the purpose of user information transfer".

5.2 Protocol stack for signalling information

Figure 3 shows how the protocols for TETRA ANF which apply at the ISI are built on top of the PSS1 protocol stack. The Remote Operation Service Element (ROSE) is used to convey ANF-ISI Protocol Data Units (PDU).

For the TETRA ANF-ISIIC and ANF-ISIGC protocols, figure 3 has to be supplemented with a direct interface to PSS1 protocol control for basic call. In addition, basic call correlation shall be ensured for the delivery of the corresponding PDUs by ANF-ISIIC and ANF-ISIGC through the protocol stack shown on figure 3, e.g. the ANF-ISIIC SETUP PDU shall have to be sent in the PSS1 SETUP message for establishing the PISN call to be used by the invoked ANF-ISIIC.

NOTE 1: The PSS1 basic call protocol is defined in ISO/IEC 11572 [12].

NOTE 2: The term "basic call correlation" has been used in the preceding clause as implicitly defined in notes to tables 3, 5, 7, and 9 of ISO/IEC 11582 [13].

Basic call correlation shall also be ensured for the delivery of specific supplementary service PDUs through ANF-ISISS, depending of the definition of those supplementary services.

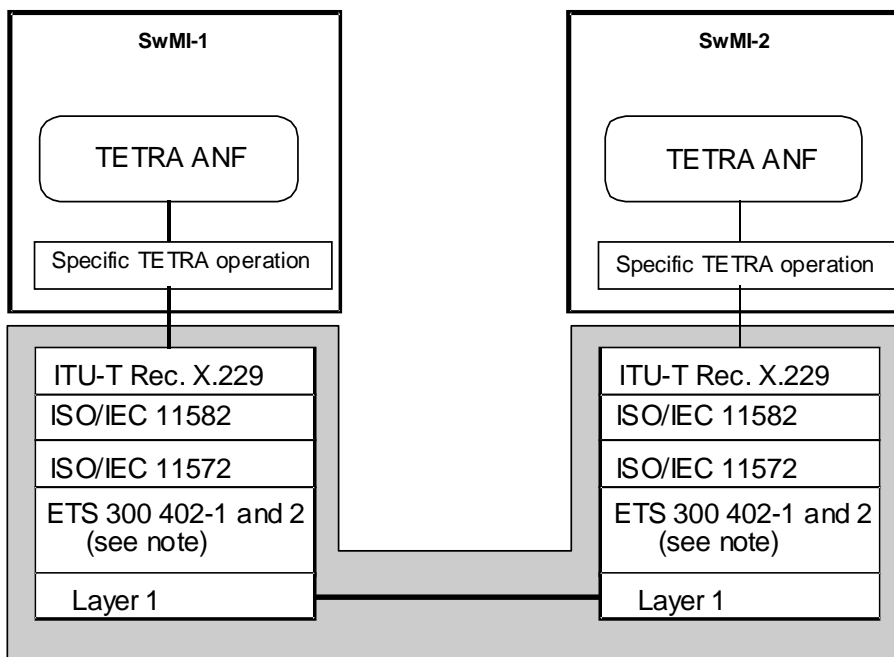

NOTE: Layer 2 protocol depends on the type of the inter-connection.

Figure 3: PSS1 protocol stack for TETRA

NOTE 3: Formally the protocol stack shown in figure 3 applies only for TETRA PDUs sent together with PSS1 basic call messages (e.g. PSS1 SETUP or CONNECT messages): i.e. the ISO/IEC 11572 [12] protocol is not part of the protocol stack for TETRA PDUs sent in PSS1 FACILITY messages - although ISO/IEC 11572 [12] is always called for, if only to establish the underlying signalling carriage mechanism - see clause 9 of ISO/IEC 11572 [12]. However, since the scope of the present document is not to define the PSS1 protocol model, it has not been judged useful to draw another figure applicable to the case of TETRA PDUs sent in PSS1 FACILITY messages, where the ISO/IEC 11572 [12] protocol would not appear.

The protocol stack shown in figure 3 is for signalling information exchange on the common signalling channel i.e. D-channel. LAPD framing as defined in ETSI ETS 300 402-1 [10] and ETSI ETS 300 402-2 [11] and for E.1, refer to Recommendation ITU-T G.704 [14], common signalling channel 16 shall be used. Protocol stack for user information exchange is presented in clause 5.4.

5.3 Generic Functional Protocol (GFP)

The GFP as defined in ISO/IEC 11582 [13] shall be used for all TETRA ANFs of the ISI (ANF-ISI).

ROSE operations shall be used to convey ANF-ISI information in facility information elements, as described in clause 8. These facility information elements shall be included in PSS1 messages in accordance with ISO/IEC 11582 [13]. The specification given in clause 7.1.1.1 of ISO/IEC 11582 [13] as to when an SwMI can send a PSS1 FACILITY message at the earliest shall be understood as follows:

- such message can be sent by a receiving SwMI after it has sent a PSS1 CALL PROCEEDING message (following reception of a PSS1 SETUP message);
- such message can be sent by a source SwMI after it has received one of the following PSS1 messages: FACILITY, PROGRESS, ALERTING, CONNECT.

When the call independent signalling connection is used, it shall be connection oriented.

NOTE: This is in line with the choice made for the definition of all existing supplementary services of the PSS1 protocols.

5.4 Protocol stack for user information

Call control manages transportation of user information e.g. TETRA coded speech on B_Q channels as presented in figure 3a. In this protocol stack the E.1 channels are 64 kbit/s channels supporting unrestricted digital information, refer to Recommendation ITU-T G.704 [14].

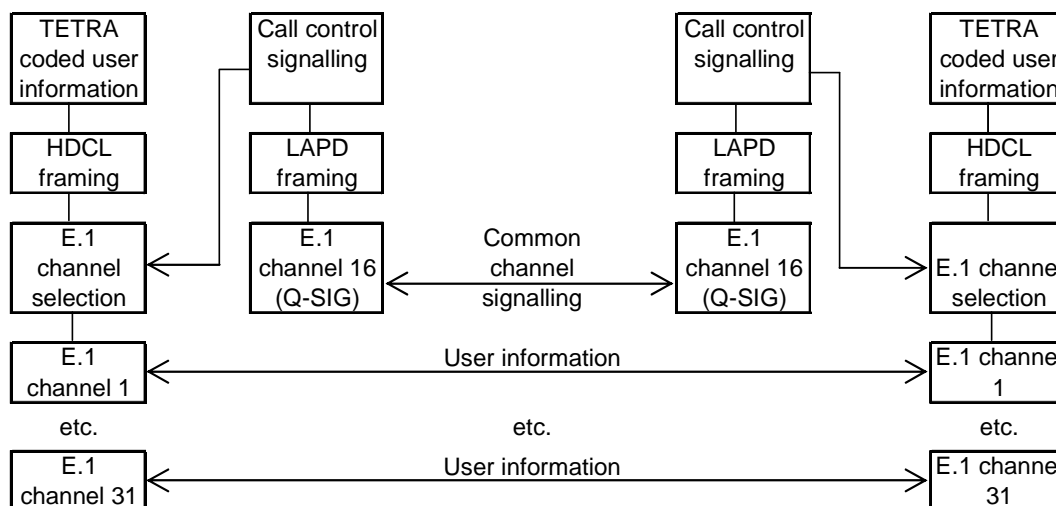

Figure 3a: User information protocol stack

For speech transmission the TETRA coded user information is speech frames that shall be carried in an E.1 channel using HDLC frames, refer to ETSI TS 100 392-3-8 [7], annex B. The call control negotiates the E.1 channel for each call instance and locally select the negotiated E.1 channel. The mapping between TETRA ISI channels and E.1 B-channels is defined in ETSI TS 100 392-3-8 [7], annex A. Call control signalling (ETSI EN 300 392-3-2 [3] and ETSI EN 300 392-3-3 [4]), LAPD framing (ETSI ETS 300 402-1 [10] and ETSI ETS 300 402-2 [11]) and E.1 common signalling channel 16 are presented in figure 3 for call control.

All or a sub-set of E.1 channels 1 to 15 and 17 to 31 shall be considered to be available for user information transport as negotiated at the QSIG connection negotiation. It can be assumed that the E.1 channels are physically connected at the same time as the LAPD connection is set-up on the common control channel and there shall be no additional E.1 channel set-up signalling at the link layer.

6 TETRA SwMI roles using ISI

6.1 Management configurations

6.1.1 Migration and group attachment configurations

6.1.1.1 SwMI roles for migration and group attachment

In order to support the Mobility Management (MM) functionality in different SwMIs for a given subscriber (whether individual subscriber or group), the following SwMI roles are defined:

- home SwMI: this home SwMI performs the subscriber MM functions related to Home DataBase (HDB). The Mobile Network Identity (MNI) of the home SwMI shall be equal to the extended part of the TSI of the subscriber (whether individual subscriber or group);
- visited SwMI: this SwMI performs the individual subscriber MM functions related to the Individual Visitor DataBase (I-VDB). By definition its MNI is different from the extended part of the TSI of that subscriber (since this SwMI is different from the subscriber home SwMI);

NOTE 1: When the individual subscriber is registered in his home SwMI, this SwMI also performs the MM functions related to the I-VDB, but in such a case except possibly for the de-registration operation, the whole MM functionality for that subscriber is supported within one single SwMI and therefore is outside the scope of ISI standardization. Regarding the de-registration operation, it will take place over the ISI in the specific case where the subscriber was previously registered in a visited SwMI and has migrated back to his home SwMI (see clause 6.1.1.3 about individual subscriber migration): but even in this case there is no need to define other SwMI roles than the two defined above (home SwMI and visited SwMI).

- group attached SwMI: this SwMI performs the group MM functions related to the Group Visitor DataBase (G-VDB). By definition its MNI is different from the extended part of the TSI of the group (subscriber) (since this SwMI is different from the group home SwMI).

NOTE 2: Generally individual subscribers will be attached to the group in the group home SwMI (actually one might expect that most of them will); this SwMI will then also perform the MM functions related to the G-VDB, but in such a case except possibly for the detachment operation of group attached SwMIs, the whole MM functionality for that subscriber is supported within one single SwMI and therefore is outside the scope of ISI standardization. Regarding the detachment operation of a group attached SwMI, it will take place over the ISI in the specific case where all individual subscribers member of the group previously registered in that SwMI have migrated away from it (see clause 6.1.1.3 about individual subscriber migration): but even in this case there is no need to define other SwMI roles than those of home SwMI and group attached SwMI defined above.

NOTE 3: Since the home SwMI of individual subscribers members of a group may be different from the home SwMI of that group, the group attached SwMIs for that group will not necessarily be visited SwMIs of the members of that group - but may also be their home SwMIs.

6.1.1.2 SwMI databases

In order to support the individual subscriber and group MM functionality in the SwMIs, the following database is defined:

- The HDB comprises information about the individual and/or group subscribers. It is located in the subscriber's home SwMI. The HDB is divided into Individual HDB (I-HDB) and Group HDB (G-HDB):
 - I-HDB contains the location tracking amongst SwMIs, i.e. in which SwMI is an individual subscriber currently located. In addition, the I-HDB is able to provide the basic and optionally the supplementary service migration profiles of the individual subscriber at migration;
 - G-HDB contains the group attachment tracking amongst SwMIs, i.e. which SwMIs are group attached. In addition, the G-HDB is able to provide the basic and optionally the supplementary service migration profiles of the group (subscriber) at group attachment.
- The VDB comprises temporary information about individual and/or group subscribers. For a given individual subscriber member of one or more groups, it is located in the SwMI where that subscriber is registered (be it his home SwMI or a visited SwMI). The VDB is divided into Individual VDB (I-VDB) and Group VDB (G-VDB):
 - I-VDB contains the Individual TETRA Subscriber Identity (ITSI) and Visiting Short Subscriber Alias Identity ((V)ASSI) association and the location tracking for the individual subscriber within the SwMI. In addition, the I-VDB is able to provide the basic and optionally the supplementary service migration profiles of the migrating individual subscriber;
 - G-VDB contains the Group TETRA Subscriber Identity (GTSI) and Visiting Short Subscriber Group Identity ((V)GSSI) association and the identities of the individual subscribers attached to the group in the SwMI. In addition, the G-VDB is able to provide the basic and optionally the supplementary service migration profiles of the attached group.
- The Authentication Centre (AC) in the home SwMI, i.e. Home Authentication Centre (HAC), may provide the authentication and Over The Air Re-keying (OTAR) parameters for the migrating individual subscriber. Similarly, the AC in the visited SwMI, i.e. the Visitor Authentication Centre (VAC), may contain the authentication and OTAR parameters provided by the home SwMI MM for the migrating individual subscriber. The HAC and the VAC are used in conjunction with the security services as described in clause 10.

NOTE: For ISI mobility configuration, the ACs (HAC and VAC) are considered as databases.

6.1.1.3 Migration scenarios

The migration is the act for an individual subscriber of moving from a Location Area (LA) in the network where that subscriber is currently registered (i.e. does have an I-VDB record) to a new LA in another network (either with different Mobile Network Code (MNC) and/or Mobile Country Code (MCC)) - where that subscriber is not registered.

Such migration from the ANF-ISI point of view shall take place:

- when an individual subscriber moves from one SwMI to another, i.e. from the SwMI where it was previously registered to a new one (be it his home SwMI or a visited SwMI);
- at power on, when the individual subscriber requests registration (migration) in a SwMI different from his home SwMI; or
- at power on, when the individual subscriber requests registration in the home SwMI and was registered at power off in another SwMI.

NOTE: From the mobile station point of view a registration is always required at power on; therefore the mobile station need not remember where it was registered at power off.

Figure 4 illustrates the ISI configuration when an individual subscriber migrates from a previous visited SwMI to new one.

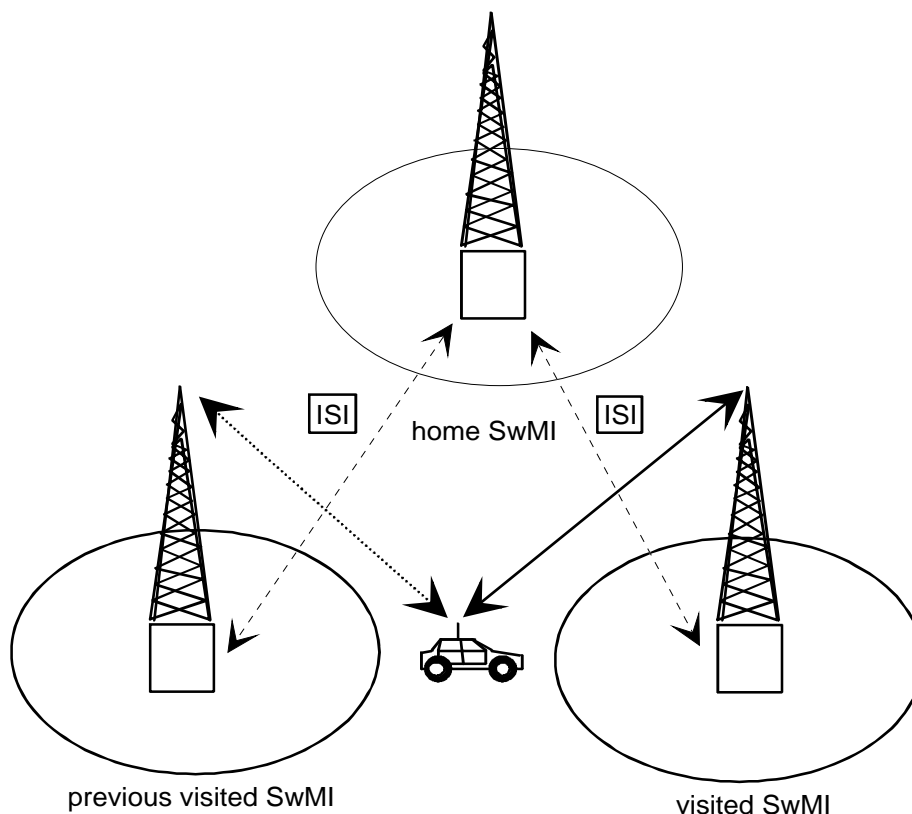

Figure 4: Migration scenario between SwMIs

At migration, the home SwMI shall update the individual subscriber's location information in the I-HDB.

The SwMI in which the migrating user has just registered (whether that SwMI is a visited SwMI or his home SwMI - in the latter case this means that the user has just migrated back into his home SwMI) shall create an I-VDB record to be used for the subscriber's location tracking within this SwMI. In addition, if that SwMI is different from the user home SwMI (i.e. it is the user visited SwMI), it shall fetch the subscriber's migration profiles (sent through ANF-ISIMM else defined by default) and save them in the I-VDB. The migration profiles shall indicate the subscriber's service authorizations during the migration in the visited SwMI. The visited SwMI shall also allocate the (V)ASSI for the individual subscriber as defined in clause 7.2.2 of ETSI EN 300 392-1 [1].

As part of the migration procedure (after the individual subscriber has been successfully registered in the SwMI into which it has just migrated), the SwMI where it was previously registered shall remove the subscriber's information from its I-VDB.

A MS/LS may contain more than one TETRA Subscriber Identity (TSI) family and the migration procedure shall have to be completed for each of them independently.

6.1.1.4 Group attachment scenarios

The group attachment procedure enables individual subscribers registered in another SwMI than the home SwMI of a group of which they are member to participate in calls to that group.

NOTE: An individual subscriber member of a group may be registered in another SwMI than the home SwMI of that group because either:

- his home SwMI is the same as that of the group and he has migrated; or
- his home SwMI is different and either he is registered in his home SwMI or he has migrated into another SwMI than the group home SwMI.

As result of the group attachment, the home SwMI shall know to which SwMIs the group call will be extended and those SwMIs will themselves handle group call set-ups.

Figure 5 illustrates the ISI configuration for the attachment to a group of which an individual user is a member, of the visited SwMI where that subscriber has migrated when the group and that subscriber have the same home SwMI.

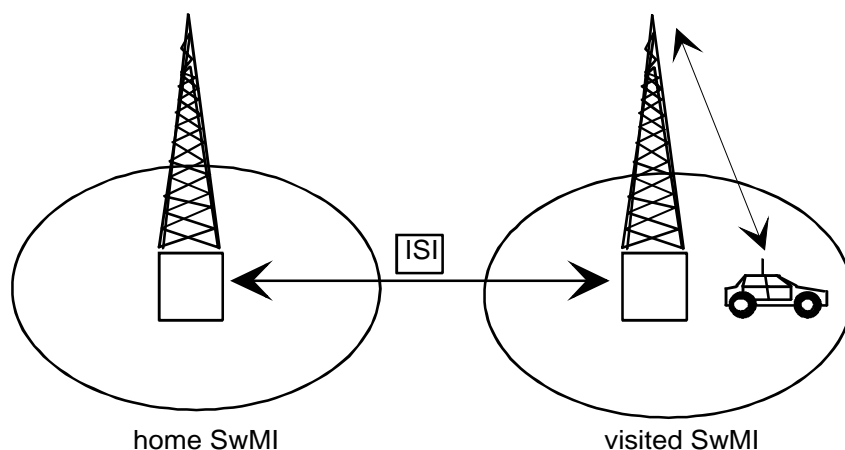

Figure 5: Group attachment scenario

When a new SwMI is attached to a group:

- the group home SwMI shall update the G-HDB with that new attachment; and
- that new SwMI shall record in the G-VDB the identity of the individual subscriber member of the group to be used for the subscribers' group attachment tracking within that SwMI and the group attachment tracking for that SwMI, i.e. which individual subscribers are attached to the group in that SwMI. In addition, that SwMI shall fetch the migration profiles for the group (sent through ANF-ISIMM else defined by default) and save them in the G-VDB. The migration profiles shall indicate the service authorizations for the group in that SwMI. That SwMI shall also allocate the (V)GSSI for the group as defined in clause 7.2.2 of ETSI EN 300 392-1 [1].

An individual subscriber may attach to one or more groups and each of those shall be attached independently.

6.1.2 Group linking configurations

The group linking shall enable the dynamic linking, i.e. combining groups with different home SwMIs (over the ISI). The call made to a group linked to another one shall result in a combined group call set-up to the members of the two groups. The combined group call is described in the document defining ANF-ISIGC.

In order to support the group linking functionality in different SwMIs, the following roles are defined for SwMIs for group linking establishment:

- linking home SwMI: The group linking home SwMI controls the making of the linking for the group, i.e. group linking. In addition, the linking home SwMI creates the group linking service profile to be used for the group linking. The group linking home SwMI is the home SwMI of one of the linked groups;
- linking participating SwMI: The group linking participating SwMI participates the group linking in linking (joining) one or more groups to the group linking. The group linking participating SwMI is the home SwMI of the linked group.

In order to support the group linking functionality in different SwMIs, the following roles are defined for SwMIs for call establishment and maintenance:

- (linking) originating SwMI: The group linking originating SwMI initiates the call to group formed by linking. The group linking originating SwMI is either the group linking controlling SwMI or the group linking participating SwMI;

NOTE: This definition assumes that only attached members of the linked groups can originate calls to the combined group formed by linking.

- linking controlling SwMI: The group linking controlling SwMI sets up the call and incorporates linking participating SwMIs to the call;
- (linking) participating SwMI: The SwMIs other than linking controlling SwMI participating the linked groups call.

In addition, the following database functionalities are defined for the SwMIs supporting group linking:

- Controlling Linking DataBase (C-LDB): The C-LDB contains the linking tracking for the linked groups, i.e. the information which groups are part of the group linking. In addition, the C-LDB contains the linking service profile for the group linking.
- Participating Linking DataBase (P-LDB): The P-LDB contains the linking tracking for one of the linked groups, i.e. the information whether the group is linked or not. The P-LDB is located in the home SwMI of the group.

From two to several groups may be linked together using group linking. Figure 6 illustrates the ISI configuration for group linking when three groups are linked together.

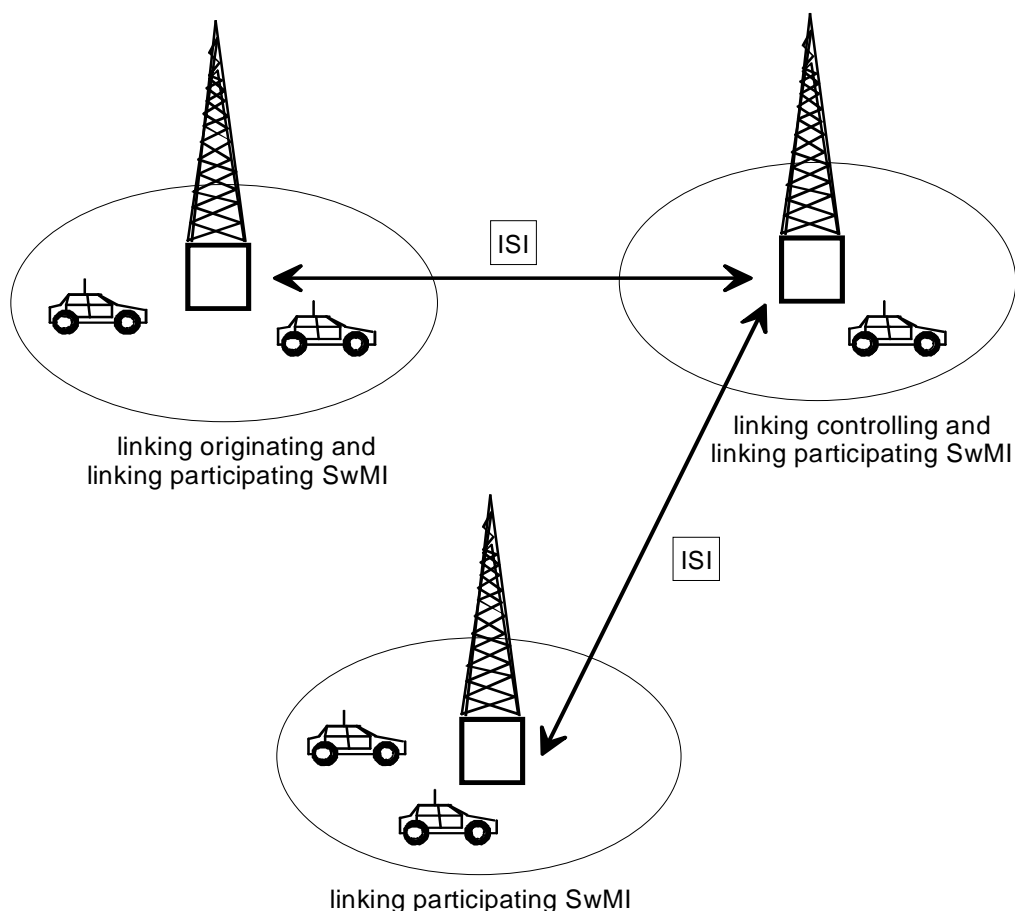

Figure 6: Group linking scenario

At group linking, the linking controlling SwMI shall co-ordinate and keep track of the group linking amongst the linking participating SwMIs. In addition, the linking controlling SwMI shall create the linking service profile for the group linking and save it to the C-LDB.

Each of the linking participating SwMIs shall link a group to the group linking and create a P-LDB record to be used for the group during the group linking.

A group can be part of only one group linking at a given time.

6.2 Call configurations

6.2.0 General

Whether it is a group call or an individual call, a call is originated by a calling user. The SwMI where that (individual) user is located is called the originating SwMI. It may or may not coincide with the home SwMI of that user.

NOTE: In the present document, the term "coincide" means "to have the same MNI".

The other possible roles for SwMIs in a group call or in an individual call where an ISI is involved are presented in the following.

6.2.1 Group call configuration

In order to support group call processing in different SwMIs, the following SwMI roles are defined, in addition to that of originating SwMI:

- controlling SwMI: the controlling SwMI shall be in charge to set up and maintain a call extending over two or more SwMIs or to deliver a short data service request involving more than one SwMI. The controlling SwMI shall be the group home SwMI (see however note 1);

- participating SwMI: an SwMI which is different from the group home SwMI and where the group call is established (see note 2).

NOTE 1: If the called group is linked to a linking group number, the linking controlling SwMI will be the home SwMI of the linking group number (and not that of the called group).

NOTE 2: To extend the group call to the participating SwMI, the controlling SwMI will have to know that at least one member of the group is registered there and attached to the group: this means that the participating SwMI will have to be attached to the group (see clause 6.1.1.4).

NOTE 3: Once the call has been established, the role of the originating SwMI will cease. Unless it coincides with the controlling SwMI, it will become a participating SwMI.

Point-to-multipoint call set-up between SwMIs shall be set-up as a logical star configuration where the controlling SwMI shall be the centre of the star.

After a user has sent his set-up request for a group call, the originating SwMI if different from the controlling SwMI shall invoke an ANF-ISIGC to pass that request to the controlling SwMI, which shall take over the establishment of the call. This shall hold regardless of whether the calling user is located or not in his home SwMI and regardless of whether the calling user is a member of the group or not. Some called users may be located in the controlling SwMI.

Figure 7 illustrates the ISI configuration when a group call is initiated between two SwMIs, the originating SwMI being the home SwMI of the group. The originating SwMI is then also the controlling SwMI.

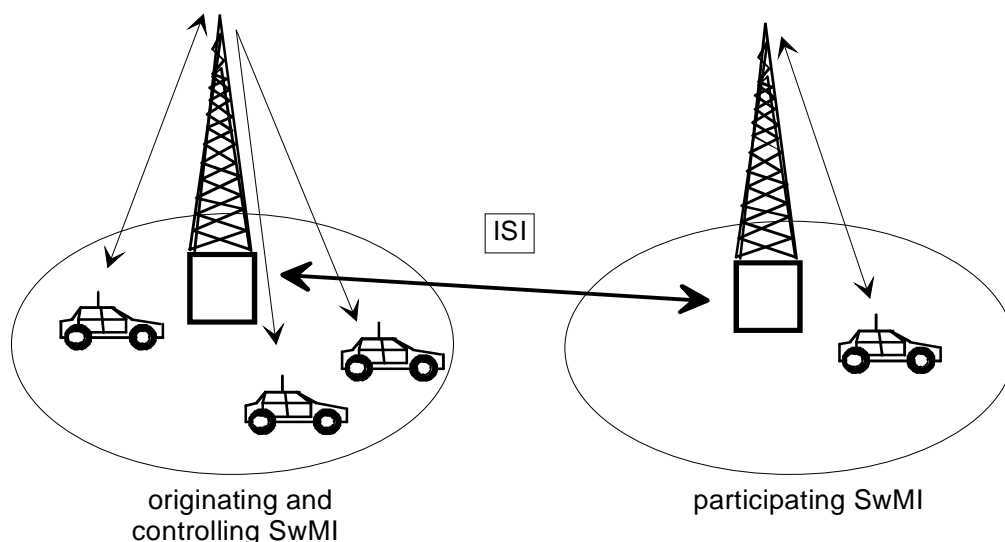

Figure 7: Group call configuration

Figure 8 illustrates the ISI configuration when the originating SwMI of a group call is not the group home SwMI. The originating SwMI becomes then a participating SwMI.

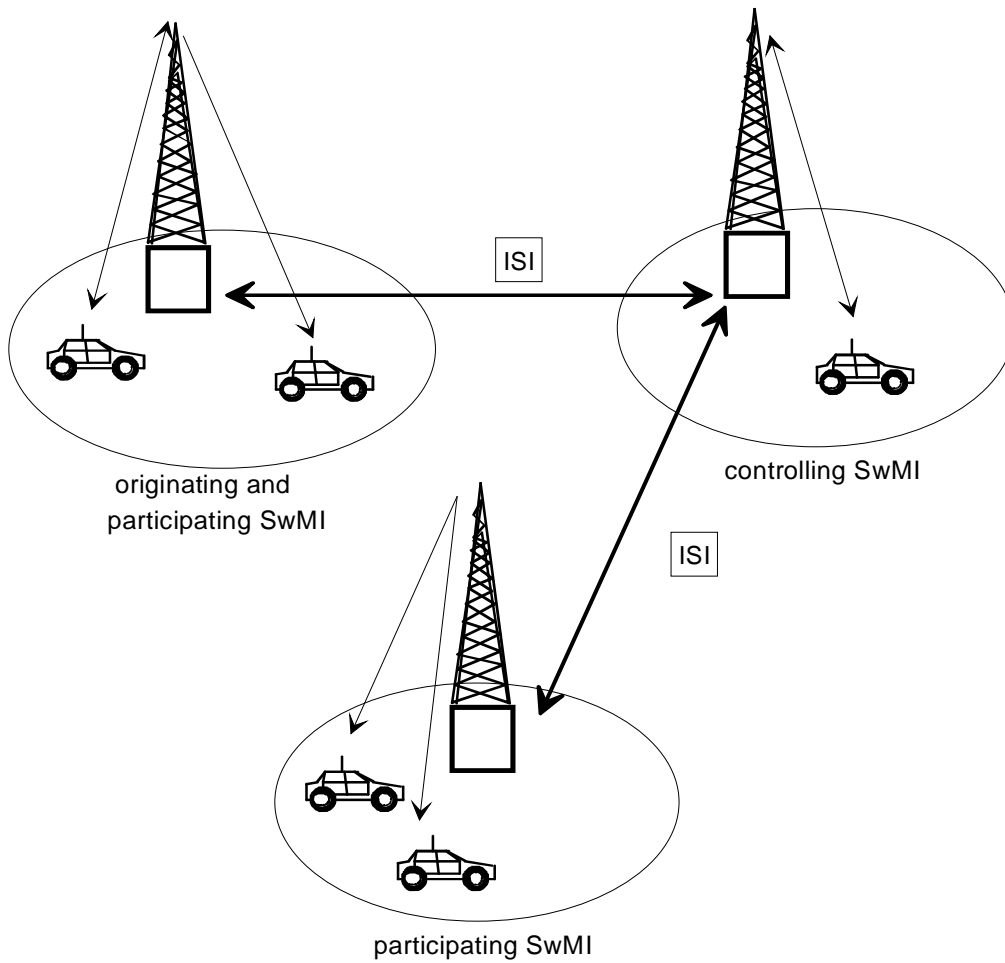

Figure 8: Group call configuration

6.2.2 Individual call configuration

When an SwMI sets up an individual call an ANF-ISIIC shall be invoked to extend this call over the ISI. Figure 9 illustrates the ISI configuration when an individual call is initiated between two SwMIs.

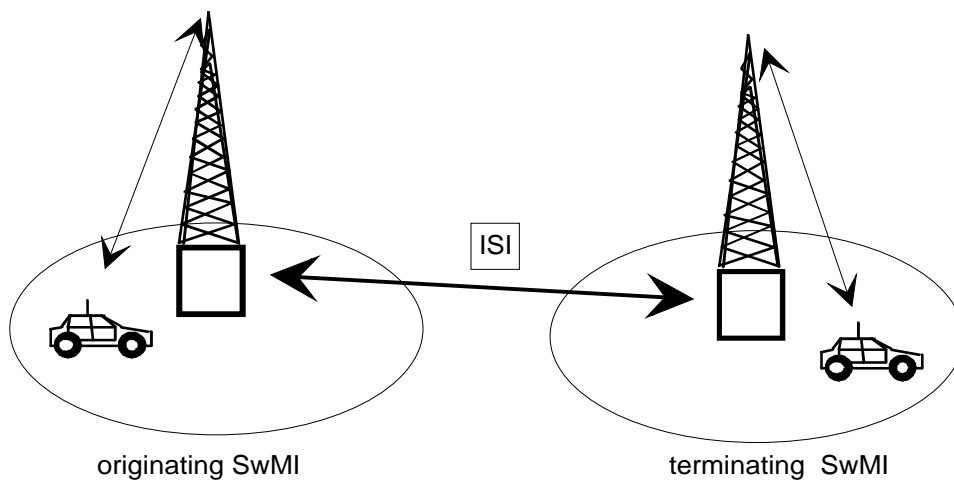

Figure 9: Individual call configuration

When a user is called, the invoked ANF-ISIIC will first route the call request to the called SwMI, this routing being independent of whether or not the originating SwMI is the home SwMI of the calling user. The invoked ANF-ISIIC will then ensure the adequate routing of the call to the terminating SwMI in the called SwMI. Three possible cases arise for this routing:

- the called SwMI is the called user home SwMI and this user has not migrated; or
- the called SwMI is the called user home SwMI and this user has migrated; or
- the called SwMI is not the home SwMI of the called user and this user has migrated (i.e. the home SwMI of this user is the originating SwMI).

The originating SwMI shall control transmission granting for half duplex operation.

NOTE: The allocation of transmission control to the originating SwMI was somewhat arbitrary; however it is more logical than to the terminating SwMI.

6.2.3 Transit

Additionally any SwMI shall have a transit capability for the following cases:

- forward switching in the case of individual call where the SwMI is the called user home SwMI and where the called user has migrated;
- call restoration;
- specific supplementary operation (e.g. call diversion).

NOTE: In addition, an SwMI may act as a standard PISN transit, but this is outside the scope of the present document.

6.3 User information encoding at the ISI

Whether in a group call or in an individual call, the user information shall be sent over ISI user information connections, which will be considered as B_Q channels by the PSS1 protocols used to establish these calls.

It has been assumed that these connections will be digital, their standard data rate being 64 kbit/s.

Clause 5.4 presents protocol stack for user information transport and its relation to the call control.

As an option multiple user information connections can be sent on a 64 kbit/s channel using virtual connections formed by addressing in the HDLC frames. At the time of writing the present document the mapping of the ISI user information connections to the virtual connections was not yet defined.

7 Introduction to ISI ANFs

7.0 General

The following ANFs will be defined for the ISI:

- Additional Network Feature - Inter-System Interface Mobility Management (ANF-ISIMM);
- Additional Network Feature - Inter-System Interface Individual Call (ANF-ISIIC);
- Additional Network Feature - Inter-System Interface Group Call (ANF-ISIGC);
- Additional Network Feature - Inter-System Interface Short Data service (ANF-ISISDS);
- Additional Network Feature - Inter-System Interface Supplementary Services (ANF-ISISS).

All their protocols will be designed so that their messages can be routed through transit PISNs, together with the associated call for those messages which are call related.

7.1 ANF-ISIMM

ANF-ISIMM enables the TETRA mobility management, authentication and OTAR services to inter-operate in different SwMIs linked through one or more ISIs. In doing so, ANF-ISIMM allows the individual subscribers e.g. to migrate, to be authenticated, to attach to groups and, thus, to participate in individual and group calls.

NOTE: The TETRA air interface MM services are defined in clause 15 of ETSI EN 300 392-2 [2], and the TETRA security authentication and the OTAR key management services in clause 4 of ETSI EN 300 392-7 [8]. However, ANF-ISIMM does not support the forward registration nor the assignment of Group Cipher key (GCK) as defined in clause 15 of ETSI EN 300 392-2 [2], and in clause 4 of ETSI EN 300 392-7 [8], respectively.

In addition, ANF-ISIMM offers database fault recovery services for SwMIs, in order to recover the databases after faulty situations, and group linking and unlinking services, in order to enable the dynamic combining of groups to support combined group calls between SwMIs.

7.2 ANF-ISIIC

ANF-ISIIC enables calls to be set-up from a TETRA user registered in one SwMI to another TETRA user registered in another SwMI, operating at the ISI of both SwMIs. It also supports call restoration when a user has migrated to another TETRA SwMI during an established call. Additionally, ANF-ISIIC allows TETRA signalling information to be passed from a TETRA SwMI to another TETRA SwMI supporting the TETRA individual call procedures as defined in clauses 11 and 14 of ETSI EN 300 392-2 [2].

7.3 ANF-ISIGC

ANF-ISIGC enables point-to-multipoint calls to be set-up between TETRA users located in more than one TETRA SwMI, operating at the ISI of all these SwMIs. It also supports call restoration when a user has migrated to another TETRA SwMI during an established call. Additionally, the ANF-ISIGC shall handle transmission control signalling from all SwMIs involved in the given group call supporting the point-to-multipoint TETRA call procedures defined in clauses 11 and 14 of ETSI EN 300-392-2 [2].

7.4 ANF-ISISDS

ANF-ISISDS enables point-to-point or point-to-multipoint short data messages to be passed between TETRA users located in more than one TETRA SwMI. SDS messages are transported using call unrelated signalling, refer to ETSI EN 300 392-3-4 [5]

7.5 ANF-ISISS

ANF-ISISS is a transport mechanism to allow signalling information exchange between two SwMIs for the control of TETRA supplementary services. It operates over the ISIs of both SwMIs - see clause 10 of ETSI EN 300 392-9 [9].

It is used e.g. for the exchange of signalling information between peer Circuit Mode Control Entities (CMCEs), as defined in clause 14 of ETSI EN 300 392-2 [2], in the specifications of a number of protocols for the operation of supplementary services.

8 ISI Generic Functional Protocol (ISI GFP)

8.1 Protocol model

The TETRA ISI is based on the PSS1 protocols stack in order to enable the interconnection of SwMIs via transit PISNs. Signalling needs for TETRA ISI operation which are not directly supported by PSS1 protocols are provided by ISI GFP.

ISI GFP does not by itself control any ANF-ISI PDUs but rather provides a means to convey them.

Figure 10 shows the conceptual model of the ISI GFP and its relationship to the various ANF entities. It is derived from figure 1 of ISO/IEC 11582 [13].

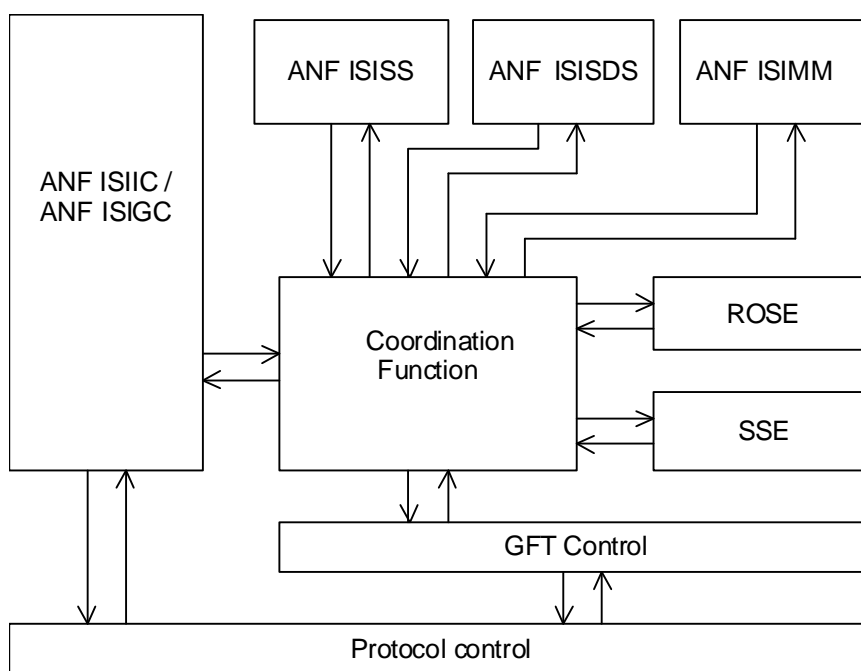

ROSE: Remote Operation Service
 SSE: Segmentation Service
 GFT: Generic Functional

Figure 10: Protocol model of the ISI Generic Functional Protocol

NOTE: Figure 10 does not take into account the establishment of call independent signalling connection (addressed in clause 8.3.2.2.1), nor its clearing (addressed in clause 8.3.2.2.3).

The entities Protocol Control (PC), Generic Functional Transport Control (GFT Control), co-ordination Function and ROSE shall exist in any SwMI which supports the ISI. The existence in an SwMI of the other entities shown on figure 10 shall depend on the ANF-ISIs supported by this SwMI.

8.2 Services provided by the protocol model entities

ANF entities (i.e. ANF-ISIIC, ANF-ISIGC, ANF-ISISDS, ANF-ISISS and ANF-ISIMM entities) use the services of the ROSE entity via the co-ordination Function in order to convey ANF-ISI PDUs through a PISN.

The corresponding ROSE primitives shall be those specified in Recommendation ITU-T X.219 [17].

If a ROSE Application Protocol Data Unit (APDU) is call unrelated and its length exceeds its possible maximum, the co-ordination Function shall address it to the Segmentation Service Element (SSE) so that this ROSE APDU can be transparently transported in spite of its length (see clause 8.5). The same shall apply for a call related for a ROSE APDU with a length exceeding its possible maximum provided that it does not have to be sent in a specific PSS1 basic call message (i.e. no basic call correlation has to be ensured for that APDU - see clause 5.2).

ROSE and SSE shall use the connection oriented services of GFT Control as defined in clause 6.7.1 of ISO/IEC 11582 [13], via the co-ordination Function. GFT Control in turn shall use the PC services as defined in clause 6.8 of ISO/IEC 11582 [13]. The corresponding PISN protocols are defined in clauses 7.1 and 7.3 of ISO/IEC 11582 [13]. The interaction between ROSE users, ROSE itself, SSE and GFT Control is co-ordinated by the co-ordination Function.

ANF-ISIIC and ANF-ISIGC use PC services for sending the PSS1 basic call messages as defined in ISO/IEC 11572 [12]. They also use the extensions of PC services and the connection oriented services of GFT Control together with the services of ROSE and of the co-ordination Function to convey their PDUs, as defined in ISO/IEC 11582 [13]. The ANF-ISIIC and ANF-ISIGC PDUs carry either:

- complementary TETRA call information, in PSS1 basic call messages; or
- TETRA call related messages, in PSS1 FACILITY messages.

Except for a few specific ANF-ISIGC PDUs, the PSS1 messages which carry the ANF-ISIIC and ANF-ISIGC PDUs are related to the PISN calls established to convey over the ISI the TETRA user information (voice or/and data) in individual or group calls respectively: i.e. except for some ANF-ISIGC PDUs, the PSS1 call related procedures defined in clause 7.1 of ISO/IEC 11582 [13] apply for the transport of the ROSE APDUs conveying the ANF-ISIIC or ANF-ISIGC PDUs.

ANF-ISIMM and ANF-ISISDS also use the extensions of PC services and the connection oriented services of GFT Control together with the services of ROSE and of the co-ordination Function to convey their PDUs, as defined in ISO/IEC 11582 [13]. However the procedures which apply for the transport of the ROSE APDUs conveying their PDUs are the connection oriented call independent procedures defined in clause 7.3 of ISO/IEC 11582 [13].

NOTE 1: No PSS1 call related procedures, as defined in clause 7.1 of ISO/IEC 11582 [13], apply for transmitting the ROSE APDUs conveying the ANF-ISIMM PDUs because all MM information is TETRA call unrelated and no need has been found to send any of that exchanged between SwMIs (over their ISIs) as PISN user information (i.e. using a B-channel, possibly more, as transmission channel for the ANF-ISIMM PDUs). Similarly for ANF-ISISDS, no need has been found to send any of the SDS information exchanged between SwMIs (over their ISIs) as PISN user information (i.e. using a B-channel, possibly more, as transmission channel for the ANF-ISISDS PDUs): i.e. although from a formal point of view the sending of SDS messages can be considered as a TETRA call (in taking the definition of a call as being the instance of a basic service and considering that SDS is a TETRA basic service), the decision has been taken not to establish any PISN call to convey SDS information over the ISI.

NOTE 2: According to the definition of the connection oriented call independent procedures in ISO/IEC 11582 [13], ROSE APDUs conveying call unrelated ANF-ISI PDUs (e.g. ANF-ISIMM or ANF-ISISDS PDUs) may be sent in the PSS1 messages which establish the related call independent signalling connection.

ANF-ISISS uses the same services as ANF-ISIMM and ANF-ISISDS for its call unrelated procedures. It uses the connection oriented services of GFT Control and the related extensions of PC services, both as defined in ISO/IEC 11582 [13], for its call related procedures.

NOTE 3: The latter statement implies that ANF-ISISS uses the signalling connections of either ANF-ISIIC or ANF-ISIGC for its call related procedure.

8.3 Addressing and transport

8.3.1 Addressing

PSS1 SETUP messages shall be addressed using PISN numbers, so that they can be routed through a PISN.

Such PISN numbers shall be defined as follows for the message concerning a given TETRA subscriber:

- for a message addressed to the home SwMI of the subscriber, the PISN number shall be defined by a routing table. Such table in a given SwMI shall have MNI entries which give the PISN number to be used for addressing messages to a SwMI;
- for a message addressed to a visited SwMI (i.e. different from the home SwMI), the PISN number shall be either:
 - that indicated by this SwMI to the home SwMI (more precisely, this PISN number will have been sent by ANF-ISIMM from the visited SwMI MM entity to the home SwMI MM entity); or
 - if such PISN number has not been sent, that corresponding to the visited SwMI MNI indicated by this SwMI to the home SwMI-MNI sent by ANF-ISIMM from the visited SwMI MM entity to the home SwMI MM entity;

this implies that to send a PSS1 SETUP message to the visited SwMI, any other SwMI than the home SwMI shall have first to get the corresponding PISN number, else the MNI of the visited SwMI, from this home SwMI;

- for a PSS1 SETUP message addressed to any other SwMI, the corresponding PISN number shall then be either:

- explicitly given; or
- determined on the basis of the SwMI MNI;
- given in some previous message.

NOTE: In other words, the definitions of the various ANF-ISI protocols have to cater for the indication of the destination SwMI PISN number to every source SwMI. The same applies also for the definitions of the supplementary service protocols which use ANF-ISISS.

The PISN numbers defined above shall always correspond to SwMIs or SwMI entities, and never to any TETRA subscriber. Unless addressed implicitly (e.g. during a call), a TETRA individual subscriber shall be addressed using its ITSI and a TETRA group using its GTSI. This ITSI or GTSI shall thus have to be included in the ANF-ISI PDUs whenever needed.

Except in a few specific cases, all other PSS1 messages will be addressed implicitly to the PINX at the end of the signalling connection over which they are sent.

8.3.2 Transport of ROSE APDUs

8.3.2.0 General

ROSE APDUs shall be included in PSS1 facility information elements as required by clause 7.1.2.1 of ISO/IEC 11582 [13] for call related ones, or clause 7.3.3.4 of the same standard (ISO/IEC 11582 [13]) for call unrelated ones.

NOTE: The corresponding APDU encoding is defined in clause 11.3.3 of ISO/IEC 11582 [13].

8.3.2.1 Call related ROSE APDUs

All call related ROSE APDUs shall be transported as defined in clause 7.1 of ISO/IEC 11582 [13] (using the signalling connection established for the corresponding call, by ANF-ISIIC, if the call is an individual call, or by ANF-ISIGC, if the call is a group call), except for the different specification as to when a SwMI can send a PSS1 FACILITY message at the earliest already provided in clause 5.3.

8.3.2.2 Call unrelated ROSE APDUs

8.3.2.2.0 General

All call unrelated ROSE APDUs shall be transported using a call independent signalling connection. If such a connection does not already exist, it shall be established as defined in clause 8.3.2.2.1; if it already exists, it may be used as defined in clause 8.3.2.2.2 or a new one shall be established.

8.3.2.2.1 Protocol for the establishment of a call independent signalling connection

The procedures to establish a call independent signalling connection are based on those defined in clause 7.3 of ISO/IEC 11582 [13], with TETRA complementary information sent as TETRA PDUs. Those procedures shall be as defined below, after the coding of their PDUs and of their information elements has first been defined.

The TETRA PDUs defined shall be conveyed as ROSE APDUs as if they were ANF-ISI PDUs (see clause 8.4.1 - using Invoke APDUs of the ROSE operation tetraIsiMessage defined in table 1).

In what follows, the SwMI which starts to establish the signalling connection shall be called the originating SwMI, the SwMI to which that connection is established shall be called the terminating SwMI.

8.3.2.2.1.1 Coding of TETRA PDUs used by the protocol for the establishment of a call independent signalling connection

The TETRA PDUs defined below shall be encoded using the same rule as defined in annex E of ETSI EN 300 392-2 [2] (for TETRA air interface PDUs).

8.3.2.2.1.1.1 TETRA PDUs in the PSS1 messages

The PSS1 SETUP message sent by the originating SwMI shall contain the first ISI PDU belonging to the nominated ANF-ISI service.

PSS1 CONNECT message sent by the terminating SwMI may include a TETRA PDU belonging to the nominated ANF-ISI service.

PSS1 FACILITY message sent by the terminating or originating SwMI shall include a TETRA PDU belonging to the nominated ANF-ISI service.

PSS1 RELEASE message may include a TETRA PDU belonging to the nominated ANF-ISI service.

8.3.2.2.1.2 Void

8.3.2.2.1.3 PSS1 facility information element containing call independent ANF ISI PDUs

The ROSE operation tetraIsiMessage referred to in the beginning of clause 8.3.2.2.1 shall be coded in PSS1 facility information elements in accordance with ISO/IEC 11582 [13]. Each such facility information element shall always include a Network Facility Extension (NFE).

The destinationEntity and sourceEntity data elements of the Network Facility Extension (NFE) shall have the value corresponding to endPINX.

The sourceEntity and destinationEntity data elements of the argument of the ROSE operation tetraIsiMessage shall have the value corresponding to CallUnrelatedSignalling.

No Interpretation APDU shall be included together with any APDU of the ROSE operation tetraIsiMessage included in PSS1 messages.

8.3.2.2.1.4 Procedures

The procedures to establish a call independent signalling connection shall be those defined in clause 7.3 of ISO/IEC 11582 [13].

If either the terminating or the originating SwMI decides to clear the call independent signalling connection being established, it shall do so according to clause 7.3.1 of ISO/IEC 11582 [13].

8.3.2.2.2 Use of a call independent signalling connection already established

A SwMI may use a call independent signalling connection already established, for sending a TETRA PDU belonging to the same ANF-ISI entity to that SwMI. Subsequent ANF-ISI messages can be sent by the terminating SwMI in the PSS1 CONNECT or by the originating or the terminating SwMI in PSS1 FACILITY messages. For how long this SwMI may use it in the specific cases is an implementation issue.

8.3.2.2.3 Clearing of a call independent signalling connection

The originating or the terminating SwMI may decide to clear a call independent signalling connection already established. However when such a connection has only recently been established, the terminating SwMI should avoid to clear it, leaving the decision to do it to the originating SwMI.

When the originating or the terminating SwMI decide to clear such connection, they shall send to the other SwMI a PSS1 RELEASE message.

NOTE: Clauses 7.3.1.1 and 7.3.1.2 of ISO/IEC 11582 [13] define call clearing conditions where a PSS1 RELEASE COMPLETE message is the first clearing message sent:

- when the PSS1 SETUP message is invalid or cannot be accepted by the PINX receiving it (clause 7.3.1.1) - a PSS1 RELEASE COMPLETE message is then sent by the PINX which has received the PSS1 SETUP message;
- when the PINX sending the PSS1 SETUP message has not received any response from the next PINX within a given time (clause 7.3.1.2);
- a PSS1 RELEASE COMPLETE message is then sent by the PINX which has sent the PSS1 SETUP message.

8.4 Remote Operations Service Entity (ROSE) requirements and operation definition

8.4.1 General

The protocol defined in Recommendation ITU-T X.882 [18] shall apply for each ROSE SwMI entity, with the exception of:

- clause 8 of this Recommendation, since the transfer services used shall be those provided by GFT Control; and
- the value of the InvokeIdType shall lie in the range (-32 768 to 32 767), instead of being unlimited, i.e. the ASN.1 type InvokeIdType defined as INTEGER in figure 1 of Recommendation ITU-T X.882 [18] shall be changed into INTEGER (-32 768 to 32 767).

NOTE 1: The two above provisions are derived from clause 8.2 and table 34 of ISO/IEC 11582 [13], respectively.

Each ANF-ISI PDU shall be encoded as an OCTET STRING in the argument of the ROSE operation tetraIsiMessage specified in table 1 using Abstract Syntax Notation One (ASN.1, 2000 version).

NOTE 2: This ROSE operation is common to all ANF-ISI protocols.

Table 1: ROSE operation in support of TETRA encoding PDU

```

TetraIsiOperation {ccitt (0) identified-organization (4) etsi (0)
                  tetra(392) isi-encoding-operation(0)}
DEFINITIONS EXPLICIT TAGS ::=

BEGIN

EXPORTS
    tetraIsiMessage;

IMPORTS
    OPERATION, ERROR
    FROM Remote-Operations-Information-Objects {joint-iso-itu-t
        remote-operations(4) informationObjects(5) version1(0)};

tetraIsiMessage OPERATION ::= {
    ARGUMENT IsiArgument
    RESULT IsiResult
    ERRORS { incompleteTetraPDU |
        requestNotSupported |
        invalidInfoElement |
        unspecified }
}

-- Definition of general used data types:
IsiArgument ::= SEQUENCE { sourceEntity [0] IMPLICIT AnfSubEntity,
    destinationEntity [1] IMPLICIT AnfSubEntity,
    tetraMessage [2] IMPLICIT OCTET STRING }

IsiResult ::= CHOICE { null NULL,
    result IsiArgument }

incompleteTetraPDU ERROR ::= {
    PARAMETER ErrorOctetString
    CODE local:1 }

itsiNotRegistered ERROR ::= {
    CODE local:2 }

itsiNotReachable ERROR ::= {
    CODE local:3 }

requestNotSupported ERROR ::= {
    PARAMETER ErrorRequestNotSupported
    CODE local:4 }

invalidInfoElement ERROR ::= {
    PARAMETER ErrorInvalidInfo
    CODE local:5 }

```

```

unspecified ERROR ::= {
    CODE local:0 }

AnfSubEntity ::= ENUMERATED {
    anfIsiss (1),
    anfIsimm (2),
    anfIsiic (3),
    anfIsigc (4),
    anfIsisd (5),
    callUnrelatedSignalling (6) }

ErrorOctetString
    ::= SEQUENCE { octetstring [0] IMPLICIT OCTET STRING }

ErrorRequestNotSupported
    ::= CHOICE {
        mmRequestNotSupported MMRequestNotSupported,
        ssRequestNotSupported SSRequestNotSupported }

MMRequestNotSupported ::= [0] OCTET STRING

SSRequestNotSupported
    ::= CHOICE {
        listSSNotSupported [1] ListSSNotSupported,
        listSSActionNotSupported [2] ListSSActionNotSupported,
        combinedSSLListNotSupported [3] CombinedSSLListNotSupported }

ListSSNotSupported ::= OCTET STRING

SSActionNotSupported
    ::= SEQUENCE {
        ssType [6] IMPLICIT OCTET STRING,
        ssPduType [7] IMPLICIT OCTET STRING }

ListSSActionNotSupported
    ::= CHOICE {
        ssAction [4] IMPLICIT SSActionNotSupported,
        ssActionSeq [5] IMPLICIT SEQUENCE OF SSActionNotSupported }

CombinedSSLListNotSupported
    ::= SEQUENCE {
        listSSNotSupported [0] ListSSNotSupported,
        listSSActionNotSupported [1] ListSSActionNotSupported }

ErrorInvalidInfo
    ::= CHOICE {
        invalidInfo [0] IMPLICIT InvalidInfoType,
        invalidInfoSeq [1] IMPLICIT SEQUENCE OF InvalidInfoType }

InvalidInfoType
    ::= SEQUENCE {
        pduIndicator [2] IMPLICIT OCTET STRING,
        elementType [3] IMPLICIT INTEGER (1..3),
        elementPosition [4] IMPLICIT INTEGER }

END -- of TetraIsiOperation

```

NOTE 3: Formally, it should be noted that when the sourceEntity or destinationEntity data elements of the argument of the ROSE operation defined in table 1 above have the value corresponding to CallUnrelatedSignalling, those entities cannot be considered as ANF entities in such a case - despite the fact that all the possible values of those entities are described in that table as corresponding to such entities (see definition of AnfSubEntity).

ROSE APDUs shall be encoded in accordance with the Basic Encoding Rules (BER) defined for ASN.1 in Recommendation ITU-T X.690 [16], with the same restrictions as defined in clause 11.4 of ISO/IEC 11582 [13].

The following data elements shall be included in the argument of the tetraIsiMessage Invoke APDU:

- element destinationEntity, which defines the destination ANF in the receiving ISI - else the destination CallUnrelatedSignalling entity (see clause 8.3.2.2.1.3 and note 3 above);
- element sourceEntity, which defines the source ANF of the Invoke APDU - else the source CallUnrelatedSignalling entity (see clause 8.3.2.2.1.3 and note 3 above);

- element tetraMessage, which contains the ANF-ISI PDU - else an ISI PDU defined in clause 8.3.2.2.1.1.

Table 2 shows an example of encoding the TETRA PDU giving complementary information in a PSS1 SETUP message for an individual call, PDU called ANF-ISIIC SETUP PDU. The column header "M/O/C" indicates which of the corresponding information elements and other components are Mandatory (M), which are Optional (O) and which are Conditional (C).

Table 2: Example of encoding complementary TETRA ANF-ISIIC information in a PSS1 SETUP message for an individual call

PSS1 SETUP message	M/O/C
Protocol discriminator	M
Call reference	M
Message type	M
Sending complete	O
Bearer capability	M
Channel Identification	M
Progress Indicator	O
Calling party number	M (note 1)
Calling party subaddress	-
Called party number	M (note 2)
Called party subaddress	-
Low layer compatibility	-
High layer compatibility	-
facility information element	
Identifier	M
Length	M
Protocol profile (Networking Extensions)	M
Network Facility Extension (NFE)	M
Network Protocol Profile	-
Interpretation APDU	M
Service APDU: ROSE INVOKE	
Identifier	M
Invokeld	M
LinkedId	-
OperationValue	M
ARGUMENT: tetraIciMessage	
SourceEntity	M
DestinationEntity	M
TetraMessage	
PDU Type	M
Selected Area Number	M
Originating SwMI MNI	M
Call has been forward switched	M
Last Forwarding SwMI MNI	C
Routeing method choice	M
SS-CF invocation counter	M
Call time-out, set-up phase	M
Call time-out	M
Hook method selection	M
Simplex/duplex selection	M
Basic service information	M
Speech service requested	C
Security level at calling user air interface	M
Call priority	M
Called/forwarded-to party address SSI	M
Called/forwarded-to party extension	M
Number of digits of called/forwarded-to external subscriber number	M
Called/forwarded-to external subscriber number	C
Calling party presentation indicator	M
Calling party address SSI	M
Calling party extension	M
Number of digits of calling external subscriber number length	M
Calling external subscriber number	C

MSISDN present as external subscriber number	C
Calling external subscriber number parameters	C
Call identified as fleet call	M
Calling party fleet number SSI	C
Called/forwarded-to party fleet number SSI	C
Override SS-CAD invocation	M
Speech services supported	O
Notification indicator	O
Proprietary	O
END of TetraMessage	
Extension	O
END of ARGUMENT	
END of Service APDU	
END of facility information element	
Notification Indicator	O
END of PSS1 SETUP message	

NOTE 1: Actually, the value put in the information element calling party number will be a PISN number in the range of numbers allocated to the originating SwMI.

NOTE 2: Actually, the value put in the information element called party number will be a PISN number in the range of numbers allocated to the called SwMI.

8.4.2 Return-result

The tetraIsmMessage ReturnResult APDU enables the receiving SwMI to return a positive reply to an Invoke APDU. It shall be used when an ANF-ISI PDU sent in the Invoke APDU needs a ROSE confirmed response. The argument of the tetraIsmMessage ReturnResult APDU shall be defined on a case by case basis (in the standard where the use of that APDU is specified).

8.4.3 Return-error

The tetraIsmMessage ReturnError APDU enables the receiving SwMI to return a negative reply, if a tetraIsmMessage Invoke APDU while still being recognized as at least partially valid cannot be accepted because of one or more of the following errors:

- incompleteTetraPdu: the received ANF-ISI PDU was incomplete because of segmentation error (see clause 8.5);
- requestNotSupported: the destination entity does not support the service requested by the ANF-ISI PDU. The use of that error indication is specified in the protocol definitions of the relevant ANFs (e.g. see clause 6.3.3 of ETSI EN 300 392-3-2 [3] for ANF-ISIIC or clause 10.3 of ETSI EN 300 392-9 [9] for ANF-ISISS). The parameter of this error is dependent on the destination entity:
 - if the destination entity is the ANF-ISIIC, there shall be no parameter (since the request not supported is clearly identifiable without any need for additional information);
 - if the destination entity is the ANF-ISIMM, the parameter shall contain the value (or the list of values) of the information element ANF-ISIMM PDU type corresponding to the ANF-ISIMM PDU(s) not supported;
 - if the destination entity is the ANF-ISISS, the parameter shall contain one or both of the two following lists:
 - for the request(s) related to SS(s) not supported, the corresponding value (or the corresponding list of values) of the information element SS type (see table 5 of ETSI EN 300 392-9 [9]);
 - for the request(s) related to action(s) not supported for specific SS(s) (which is (are) supported), the corresponding values (or the corresponding list of values) of the information elements SS type and SS PDU type (see tables 5 and 6 of ETSI EN 300 392-9 [9]);

NOTE: At the time of writing the present document, no use has been defined (yet) for the error indication requestNotSupported in the protocols for ANF-ISIGC, ANF-ISIMM and ANF-ISISDS.

- **invalidInfoElement**: at least one element of the ANF-ISI PDU cannot be understood. For each such PDU the first invalid information element detected shall be indicated by the parameter of this error using the following three pieces of information:
 - the ANF-ISI PDU identification, i.e.:
 - for ANF-ISISS: the corresponding values (or the corresponding list of values) of the information elements SS type and SS PDU type (see tables 5 and 6 of ETSI EN 300 392-9 [9]);
 - for other ANF-ISI PDUs: the corresponding value (or the corresponding list of values) of the information element PDU type;
 - the type of the first element of this PDU which was not understood;
 - the position of this element in the list of information elements of the same type present in the PDU (e.g. third type 1 element in some specific SS PDU received);

the above three pieces of information shall be repeated in the parameter of the error **invalidInfoElement** for each ANF-ISI PDU in which one invalid information element has been detected by the receiving SwMI;
- unspecified.

If one error listed above has occurred, the **ReturnError** APDU shall be sent with the appropriate error value, and its possible associated parameter value. If more than one has occurred, the error value sent shall specify only one error, and the parameter value, the parameters possibly associated with this error. This single error shall be chosen according to their priority, this priority being defined by their rank in the above list, e.g. if the error **incompleteTetraPDU** has occurred (because of segmentation error), it shall be the error indicated, and if no error **incompleteTetraPDU** has occurred and if **requestNotSupported** has occurred, the latter shall be the error indicated.

The decision taken by the originating SwMI when its ROSE entity receives a **returnError** APDU when the terminating SwMI has not already cleared the call independent signalling connection is an implementation matter (in most cases it will clear that connection; and may or may not attempt to establish it later).

8.4.4 Reject

As part of its compliance with Recommendation ITU-T X.882 [18] (see clause 8.4.1), each ROSE SwMI entity shall support the reject procedures specified in this recommendation. A specific use of a reject reason has been defined in clause 8.6.

NOTE: Another example of user-reject reason is when the destination entity or source entity data elements are invalid. This case corresponds to a problem parameter of type **InvokeProblem**, with the value **mistypedArgument**.

The decision taken by the originating SwMI when its ROSE entity receives a **reject** APDU when the terminating SwMI has not already cleared the call independent signalling connection is an implementation matter (in most cases it will clear that connection; and may or may not attempt to establish it later).

8.5 Segmentation Service Element (SSE)

8.5.0 Overview

SSE shall take ROSE APDUs divide them into segments which fit into a single facility information element and send these segments in SSE APDUs to the peer SSE. The peer SSE shall re-assemble the original ROSE APDU and deliver it to the destination ROSE entity.

The length of a segment is related to the maximum length of a facility information element (which is 255 octets, see clause 11.3.3 of ISO/IEC 11582 [13]) and it depends on the maximum length of a layer 2 PDU. As a result, the segment length varies - see annex B.

8.5.1 Procedures

8.5.1.0 General

The clause 8.5.1 specifies two procedures for SSE: segmentation and re-assembly. Those procedures are based on the segmentation and re-assembly procedures defined in annex ZA of ISO/IEC 11572 [12].

NOTE: According to the requirements defined in clause 8.2 for the co-ordination Function to address a ROSE APDU to SSE, segmentation procedures will not be applied to a ROSE APDU:

- which fits into a single facility information element; or
- which has to be sent in a specific PSS1 basic call message.

8.5.1.1 Requirements for the segmentation procedure

Once the first segment has been transmitted to GFT Control, then all remaining segments of that message shall be sent in order, before any other ROSE APDU (segmented or not). After sending a segment, the timer T1 shall be started and before it expires the subsequent segment shall be sent. Only failure conditions (e.g. GFT Control failure or timer T1 time-out) shall cause the transmission of a segmented ROSE APDU to be aborted.

The ROSE message identifier field in the segmented message shall identify the ROSE APDU to which the segment belongs; this identifier is uniquely defined by SSE and it is not related to the invokeId included in the ROSE APDU.

The remaining segments field of the segmented message information element shall indicate how many more segments are to be sent.

The octet order of the segmented ROSE APDU shall be preserved regardless of segment boundary.

The protocol timer definition in table 3 shall apply for the segmentation procedures.

Table 3: Timer definition for segmentation procedure

Timer number	Timer value	Cause for start	Normally terminated	Action to be taken when timer expires	Status
T1	Max. 100 ms	Message segment sent	Subsequent segment message sent	Transmission of the segmented ROSE APDU aborted	Mandatory

8.5.1.2 Requirements for the re-assembly procedure

The re-assembly function on receiving a segment in which the remaining segments field is not set to zero (last segment of a segmented ROSE APDU) shall save the segment contents and shall start a timer T2.

NOTE: This timer T2 is used to prevent the re-assembly function waiting indefinitely to receive the next message segment.

SSE shall be able to re-assemble received segments of any size.

When receiving an invalid segment, SSE shall discard this segment and send the incomplete message to ROSE. A Reject APDU or a ReturnError APDU with the value IncompleteTetraPDU shall also be send to the source SwMI.

An invalid segment could be one of the following:

- segment in which the number of remaining segment field of the segmented message has a value which is not one less than the value of the previously received segment;
- segment which is not the first segment of a segmented ROSE APDU with an identifier value different from that in the previously received segment.

On expiry of timer T2, the re-assembly function shall send any saved segment to ROSE entity and inform it at the same time that the transmitted message is incomplete. The re-sending of the ROSE APDU is an implementation matter.

The protocol timer definition in table 4 shall apply for the re-assembly procedures.

Table 4: Timer definition for re-assembly procedure

Timer number	Timer value	Cause for start	Normally terminated	Action to be taken when timer expires	Status
T2	Max. 200 ms	Message segment received	Last message segment received	Send message to ROSE with error handling	Mandatory

8.5.2 Segment encoding

SSE segment shall be included in a (PSS1) facility information element as defined in clause 11.3.3 of ISO/IEC 11582 [13], with a new type of Service APDU: the SSE APDU, the definition of the information element network protocol profile, in table 29 of ISO/IEC 11582 [13]) being correspondingly superseded with that in table 5, in order to add a new value for that information element, allowing to indicate that the service APDU included in the (PSS1) facility information element is a SSE APDU.

Table 5: Network protocol profile

```

Network-Protocol-Profile-definition
{ccitt (0) identified-organization (4) etsi (0) tetra(392) network-protocol-profile-definition(1)}
DEFINITIONS ::=
BEGIN
EXPORTS NetworkProtocolProfile;
NetworkProtocolProfile ::= [18] IMPLICIT INTEGER
    {
        acse(19)
        dse (32)
        tetraSse(39) } (0..254)
END -- of Network Protocol Profile definition

```

Obviously, only one SSE APDU can be included in the service APDU of the facility information element. The protocol profile value of this facility information element shall be set to Networking Extensions and the NFE shall be included with the same data elements values which would have applied for sending the ROSE APDU if it had been possible to send it without segmenting it (see clause 8.3.2.2.1.3).

A SSE APDU shall comprise ASN.1 type as defined in table 6.

Table 6: ASN.1 definition of SSE APDU

```

Sse-Apdu-definition
{ccitt (0) identified-organization (4) etsi (0) tetra(392) sse-apdu(2)}
DEFINITIONS ::=
BEGIN
EXPORTS SseApu
SseApu ::= [39] IMPLICIT OCTET STRING
END -- of SSE APDU definition

```

The structure of the octet string included in a SSE APDU shall be as defined in table 7.

Table 7: Structure of SSE APDU

Information element	Length	Type	C/O/M	Remark
ROSE message identifier	8	1	M	Identifies the ROSE APDU the segment belongs to (see note 1).
Remaining segments	8	1	M	Indicates how many segments follow (see note 2).
Data		1	M	Segment of the ROSE APDU (see note 3).
NOTE 1: The message identifier is assigned by the sending SSE. It shall be unique on that signalling connection and can be reused when the transfer of the respective ROSE APDU has been completed.				
NOTE 2: The counter provides a means to verify the proper transmission of the ROSE APDU. It shall count down to 0, thus indicating the last segment.				
NOTE 3: To generate this information element, SSE shall simply consider the ROSE APDU as a bit string.				

8.6 Co-ordination Function

The co-ordination Function provides co-ordination between GFT Control, the different ANF entities, ROSE and SSE. This co-ordination includes the delivery of information received from the GFT Control to its destination entity. It also includes the allocation of the ROSE Invoke identifier for each request addressed by an ANF-ISI to the ROSE entity.

NOTE 1: Since the same ROSE operation (defined in table 1) is used by all ANF-ISI entities, the allocation of the ROSE Invoke identifier has to be common to all those entities: only the co-ordination Function can do it.

The co-ordination Function also supports the handling of unrecognized APDUs.

The relationships it co-ordinates are beyond the scope of the present document.

When a ROSE Invoke APDU is addressed to an ANF-ISI entity which is not present in the receiving SwMI, the co-ordination Function shall request the ROSE entity to generate a Reject APDU of type InvokeProblem with the value unrecognizedOperation.

In addition, the co-ordination Function requirements defined in clause 8.1 of ISO/IEC 11582 [13] shall apply. Notably, according to clause 8.1.2 of ISO/IEC 11582 [13], when the ROSE entity has generated a Reject APDU of type InvokeProblem with the value unrecognizedOperation as a result of an Invoke APDU sent in a facility information element with an Interpretation APDU with the value clearCallIfAnyInvokePduNotRecognized, the co-ordination Function will clear the TETRA call or the call independent signalling connection. It will also ensure that the Reject APDU is delivered to its destination.

NOTE 2: As a consequence of the two preceding clauses, when such interpretation APDU has been included in a facility information carrying an Invoke APDU addressed to a non-existing ANF-ISI entity during an inter-TETRA call, the co-ordination Function will clear this call.

9 Security over the ISI

9.0 General

Authentication and encryption of the connections used between SwMIs are outside the scope of TETRA standardization. However ITSI authentication, end-to-end encryption and end-to-end key management have impact on the ISI.

In addition, the specific requirements on ANF-ISIMM to support air interface encryption in a visited SwMI for an individual subscriber (i.e. when this SwMI is different from his home SwMI) are defined in annex A. This annex includes also a supporting explanation for the various possible types of cipher key which may be used at the air interface and their relationship with authentication.

9.1 ITSI authentication

When migrating, an individual subscriber may have to be authenticated by the visited SwMI, if this SwMI and the subscriber's home SwMI both support this option. To support it, upon request from the visited SwMI using ANF-ISIMM, the home SwMI shall send the authentication parameters over the ISI to the visited SwMI also using ANF-ISIMM. Those authentication parameters are a session key for each of MS and SwMI authentication (KS and KS') and a Random Seed (RS) used to seed the authentication algorithm.

The home network shall send those authentication parameters only once to a visited SwMI for an MS. This visited SwMI may then use them for authentication, using the procedure defined in clauses 4.2 and 4.3 of ETSI EN 300 392-7 [8]. This procedure may be repeated within the time limits advised by the home SwMI.

NOTE 1: This method which does not reveal the original authentication key of the MS combines security and efficiency.

The same authentication parameters sent by the home SwMI allow an individual subscriber which has migrated to authenticate the infrastructure, using the procedure defined in clause 4.3 of ETSI EN 300 392-7 [8]. Formally, this procedure shall only authenticate the home SwMI. But by acting as an agent to the authentication process the visited SwMI is implicitly authenticated.

NOTE 2: In a symmetric key authentication process there is authentication only between the holders of the key (in this case the MS and the home SwMI of that MS). If an intermediary holds some of the data, or performs part of the process, then the home SwMI is in effect distributing its management function to that intermediary. In the ISI case the intermediary is the visited SwMI and is essentially part of a distributed home SwMI. It can therefore be trusted. In such an instance the visited SwMI is trusted in the same way that a BS within the home SwMI is trusted.

9.2 End-to-end encryption

There is no end-to-end encryption algorithm or method defined for TETRA. However a mechanism is described to support the synchronization of synchronous stream ciphers, with synchronization data sent interspersed with the encrypted voice or data traffic. The frequency at which such signalling can be sent is defined in clause 7 of ETSI EN 300 392-7 [8]. This synchronization data has to be correlated in a bit exact manner to the encrypted traffic. This is ensured at the air interface by using the frame stealing mechanism. To ensure it over the ISI, an in-band signalling method shall be used between the source and the destination SwMIs. This method shall be such that the destination SwMI of the call shall receive stolen frames from the source SwMI in such a sequence that it shall be able to correctly transmit these across the air interface, i.e. the exact relation between stolen frames and the first and second half slots of a timeslot shall be maintained.

This implies that frame and timeslot boundaries, and ordering, shall be retained across the ISI for end-to-end encrypted calls.

NOTE: A similar requirement exists for voice calls, between TETRA codecs (see ETSI EN 300 395-1 [i.1]).

9.3 End-to-end key management via ISI

Clause 7.6 of ETSI EN 300 392-7 [8] provides a means of transporting end-to-end key management material over the air interface by use of short data messages. The quantity of data transported is 2 047 bits minus a data type identifier, which corresponds to the maximum length of a type 4 short data message. To allow the extension of such messages over the ISI between SwMIs, ANF-ISISDS shall be supported.

Annex A (normative): Security - supporting encryption over ISI

A.1 Overview

This annex describes the support of air interface encryption by transmission of security parameters over the ISI. The material presented here also describes the major differences between support of security functions over the ISI, and the support of the same functionality at the air interface.

Air interface encryption takes place in layer 2 of the air interface protocol stack. The layer 3 authentication service, embedded in MM, can provide a cipher key to layer 2 that is strongly bound to authentication (i.e. it allows implicit authentication of all messages sent that are encrypted using this key). In addition the layer 3 OTAR service, embedded in MM, can provide cipher keys to layer 2.

The air interface authentication mechanism uses a secret key schema that ensures that the authentication Key (K) is known only to the AC and the user. In order to enable authentication of migrated users, the home SwMI and the visited SwMI shall support the ANF-ISIMM functionality allowing authentication of a (individual) subscriber in a visited SwMI. As described in clause A.2.2.2, at the same time, this will allow the visited SwMI to support the air interface encryption service using Derived Cipher Key (DCK) for a user having migrated. If, instead of this air interface encryption service, the visited SwMI supports the air interface encryption service using Static Cipher Key (SCK) (see clause A.2.2.4), in order to enable migrating users to use this service, the home SwMI and the visited SwMI shall support ANF-ISIMM functionality OTAR SCK for a subscriber in a visited SwMI.

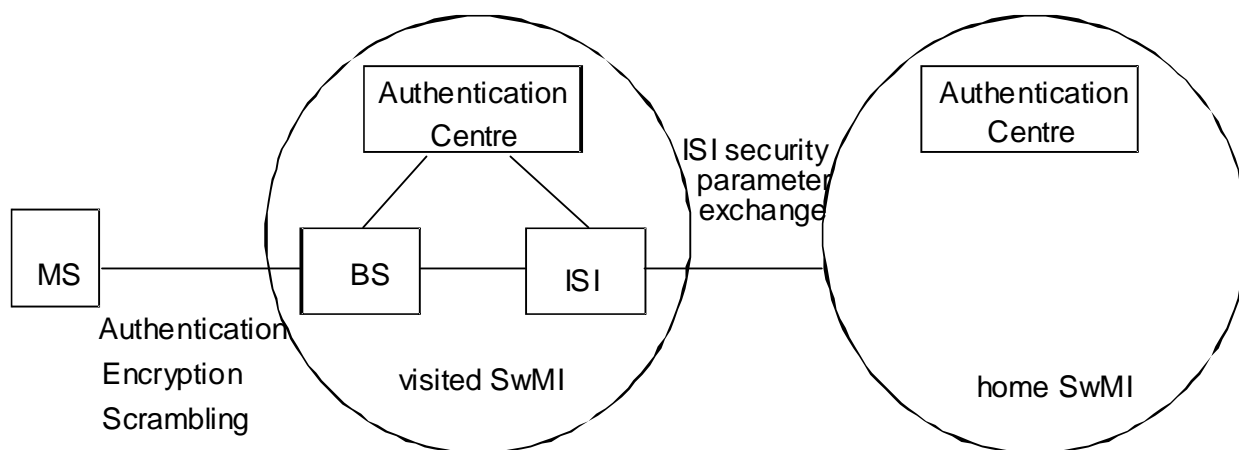

NOTE: BS = Base Station.

Figure A.1: Overview of ISI in place within TETRA

In figure A.1 the AC holds the ITSI/secret key K relationship and is a trusted part of the SwMI, see ETSI EN 300 392-7 [8]. By authenticating the individual subscriber to the network and then using the authentication process to derive an encryption key the air-interface is made secure and this individual subscriber becomes trusted. The ISI is not secure although it is allowed to carry authentication parameters and signalling data. The corresponding ISI path is implicitly trusted if authentication is successful.

When migrating, an individual subscriber may have to be authenticated to the visited SwMI. This shall be achieved by the ISI supporting transport of authentication parameters from home SwMI to visited SwMI.

A.2 Encryption

A.2.1 ISI relation to air interface and end-to-end encryption

The air interface encryption system in TETRA (see ETSI EN 300 392-7 [8]) operates on the radio link between individual subscriber and BSs of the SwMI. The cipher keys may be dynamically derived. Encryption synchronization will be derived from the frame numbering system. As this encryption applies at the air interface, information will be decrypted at the BSs of the SwMI, and therefore will be unencrypted at point of presentation to the ISI.

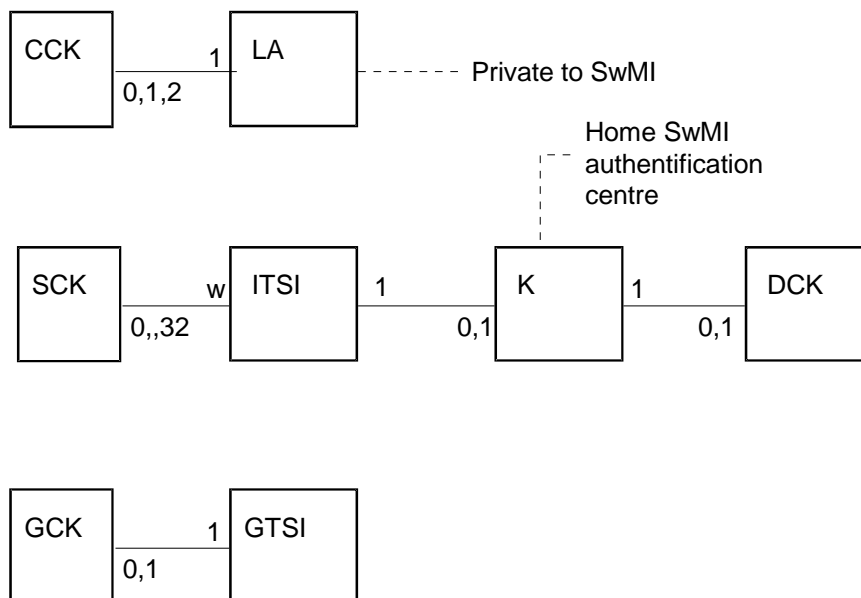

- NOTE 1: The relation between the SCK and ITSI allows up to 32 keys to be associated with any ITSI but SCKs may not be shared among ITSIs.
- NOTE 2: Only one Common Cipher Key (CCK) shall be in use at one time in an LA.
- NOTE 3: The cardinality of each relation is shown by the figures attached to each link, e.g. an ITSI can have 1 or 0 keys K, and K can be associated with only one ITSI. An open relation is shown by a letter (e.g. "w" for SCK to ITSI).

Figure A.2: Mapping of cipher key and TETRA address relationships

In order to use encryption at the air interface, the serving BS and the individual subscriber shall have the same keys. Figure A.2 shows the relation of cipher keys to addresses. For the ISI to be invoked for the transfer of a key, and for the air interface service OTAR to be invoked, the address use has to be allowed in the visited SwMI.

End-to-end encrypted traffic between individual subscribers shall remain encrypted across the ISI. End-to-end encryption does not encrypt signalling.

A.2.2 Air interface encryption key management via ISI

A.2.2.0 General

In ETSI EN 300 392-7 [8] a mechanism of key management over the air interface is described i.e. OTAR. This mechanism allows the SwMI to distribute keys to individual subscribers. Each key is sealed prior to distribution: i.e. it is packaged in an encrypted form where the key to be used is derived from the secret key K.

The keys that are used for air interface encryption are described in relationship to the ISI in the following clauses.

- NOTE: This description is given in more detail in the ETSI EN 300 392-3-5 [6] defining ANF-ISIMM.

A.2.2.1 Secret Key of individual subscriber (K)

K shall not be transferred over the ISI.

A.2.2.2 Derived Cipher Key (DCK)

Authentication is a prerequisite of DCK.

The DCK shall be generated within the SwMI where the individual subscriber has requested registration. It shall not be valid in a different SwMI, and shall be generated afresh by authentication when an individual subscriber requests registration in a new SwMI. It shall not be transferred across the ISI.

In order to support the use of DCK in the visited SwMI ANF-ISIMM shall support the transfer of DCK generator parameters from the AC of the home SwMI of the migrating individual subscriber. These parameters shall consist of the session key for individual subscriber authentication, the session key for SwMI authentication and the random seed. These parameters are used in the authentication algorithms which as an output of successful authentication allow DCK to be generated. The terms authentication parameters and DCK generator parameters are equivalent and should be used to reflect the user intention.

A.2.2.3 Common Cipher Key (CCK)

Authentication is a prerequisite of CCK.

The CCK shall be generated within an SwMI and shall be valid within one or more LAs of that SwMI. It shall not be known within a different SwMI. If an individual subscriber migrates and request registration in a new SwMI, it shall be authenticated by this SwMI, and obtain the relevant CCK within that new SwMI. The CCK shall not be transported via the ISI.

A.2.2.4 Static Cipher Key (SCK)

The SCK may be valid in many SwMIs and may require to be modified from the home SwMI across the ISI. In addition the visited SwMI may require to distribute versions of SCK to all registered users of its SwMI.

The visited SwMI may generate SCK locally. In order to distribute this locally generated SCK, ANF-ISIMM shall support the transfer from the home SwMI to the visited SwMI of parameters to allow the SCK to be sealed. These parameters shall be:

- Session Key for OTAR; and
- RS for OTAR.

The home SwMI may wish to distribute a new SCK to a migrating subscriber. Such a key shall not be used by the visited SwMI, but only in the home SwMI. The home SwMI shall then request ANF-ISIMM to transfer the sealed key and the parameters to allow the migrating individual subscriber to unseal it. These parameters shall be:

- RS for OTAR;
- SCK number; and
- SCK version number.

A.2.2.5 Group Cipher Key (GCK)

Authentication is a prerequisite of GCK.

For secure group calls in an SwMI there shall be a key, GCK, associated with the group address (GTSI).

In a visited SwMI a GCK shall only be used if it is generated and assigned by the visited SwMI. This shall not invoke ANF-ISIMM.

Annex B (informative): Maximum length of a ROSE APDU or a SSE segment encoded in a facility information element

B.0 General

The maximum length of a ROSE APDU or a SSE segment is related to the maximum length of a facility information element (which is 257 octets - see clause 11.3.3 of ISO/IEC 11582 [13]) and it depends also on the maximum length provided for by PSS1 segmentation (see annex ZA of ISO/IEC 11572 [12]). The minimum length of the PSS1 PDU ensured by this segmentation is 260 octets.

Some examples of the maximum lengths of ROSE APDUs or SSE segments encoded in a facility information element in different PSS1 messages are given in the following clauses. The hypothesis taken is that the maximum possible length of PSS1 messages is only 260 octets.

In the tables the column header "M/O" indicates which of these information elements are Mandatory (M), which are Optional (O). The column headed "Length" indicates the length of the information elements in octets.

B.1 PSS1 FACILITY message

Table B.1 shows an example of encoding a ROSE APDU or a SSE segment in a PSS1 FACILITY message, whether call related or call unrelated.

**Table B.1: Example of encoding a ROSE APDU or a SSE segment
in a PSS1 FACILITY message**

PSS1 FACILITY message	M/O	Length	Note
Protocol discriminator	M	1	
Call reference	M	3	
Message type	M	1	
Facility information element			
Identifier	M	1	
Length	M	1	
Protocol profile (Networking Extensions)	M	1	
NFE	M	8	1
Network Prot Profile	O	0/3	2
Interpretation APDU	O	0	3
Service APDU: ROSE APDU or SSE Segment			
END of facility information element			
END of PSS1 FACILITY message			

NOTE 1: The length of 8 octets indicated in the table for the NFE information corresponds to the case where the destinationEntity and the sourceEntity data elements both contain the value endPINX.
NOTE 2: The Network protocol profile is not included for a ROSE APDU (0 octet). It is included for a SSE segment; in that case it is encoded in 3 octets.
NOTE 3: The Interpretation APDU information element may be omitted or included with the value "rejectAnyUnrecognizedInvokedPdu". In this example it is omitted.

In order to encode a ROSE APDU in a PSS1 FACILITY message, 5 octets are used for the encoding of the PSS1 message and 11 for the encoding of the facility information element. Of the two length limits of 260 octets per PSS1 message and 257 octets per facility information element, the more stringent in that case is the first one. It results in the maximum length of a ROSE APDU being 244 octets in that case, that of a SSE segment being 241 octets.

B.2 PSS1 basic call message

In a PSS1 basic call message, there are more data element compared to a PSS1 FACILITY message. It is assumed that the PSS1 SETUP message is the most critical message regarding the length. Table B.2 shows an example of encoding a ROSE APDU sent in such PSS1 SETUP message (whether for an individual call or for a group call).

Table B.2: Example of encoding a ROSE APDU in a PSS1 SETUP message

PSS1 SETUP message	M/O	Length	Note
Protocol discriminator	M	1	
Call reference	M	3	
Message type	M	1	
Sending complete	O	1	
Bearer capability	M	4	
Channel Id	M	6	
Progress	O	0	1
Calling PN (SwMI PISN)	M	21	2
Calling subaddress	-	0	
Called PN (SwMI PISN)	M	21	2
Called subaddress	-	0	
Low layer compatibility	-	0	
High layer compatibility	-	0	
Facility information element			
Identifier	M	1	
Length	M	1	
Protocol profile (Networking Extensions)	M	1	
NFE	M	8	3
Network Prot Profile	-	0	
Interpretation APDU	O	3	4
Service APDU: ROSE APDU			
END of facility information element			
END of PSS1 SETUP message			

NOTE 1: In this example it is proposed not to include any optional information element.
NOTE 2: According to Recommendation ITU-T E.164 [i.4], the maximum length of a PSTN international number is 15 digits (and 12 for a national number), then it is necessary to add 3 digits for the prefix before the international number. The length of the heading (identifiers, length) of the PSS1 information elements calling party number and called party number is 3 octets, to which 1 octet per digit is added.
NOTE 3: The length of 8 octets indicated in the table for the NFE information corresponds to the case where the destinationEntity and the sourceEntity data elements both contain the value endPINX.
NOTE 4: The Interpretation APDU information element will be included with the value "clearCallIfAnyInvokedPduNotRecognized".

In order to encode a ROSE APDU in a PSS1 SETUP message, up to 58 octets may be used for the encoding of the PSS1 message (although it is highly unlikely that the PISN of the called SwMI or that of the originating SWMI will ever need 21 octets) and 14 for the encoding of the facility information element. Of the two length limits of 260 octets per PSS1 message and 257 octets per facility information element, the more stringent in that case is the first one. It would result in the need to limit the length of a ROSE APDU sent in a PSS1 SETUP message to 188 octets.

NOTE: If the PISN of the called SwMI and that of the originating SWMI are each encoded with less than 21 octets, the limit length of a ROSE APDU sent in a PSS1 SETUP message will be increased accordingly.

B.3 Example of the encoding of an ANF-ISIMM MIGRATION PDU in a ROSE Invoke ROSE APDU in a call PISN FACILITY PDU

Table B.3 shows an example of encoding the ANF-ISIMM MIGRATION PDU in a PISN FACILITY PDU in a call unrelated connection.

Table B.3: Example of encoding an ANF-ISIMM MIGRATION PDU in a ROSE Invoke ROSE APDU in a call PISN FACILITY PDU

QSIG FACILITY PDU	Definition of the value	Value
Protocol discriminator	Recommendation ITU-T Q.931 [15]	00001000 ₂
Call reference	dummy call reference	00000000 ₂
Message type	FACILITY	01100010 ₂
Information Element		
Information element identifier	facility	00011100 ₂
Length	length = 46	00101110 ₂
Protocol profile (ROSE)	Networking extension	10011111 ₂
Network Facility Extension		
sourceEntity	Context specific-constructed-tag 10	10101010 ₂
	Length = 6	00000110 ₂
sourceEntityAddress	Context specific-primitive-tag 0	10000000 ₂
	length = 1	00000001 ₂
destinationEntity	endPINX	00000000 ₂
	OMITTED	
destinationEntityAddress	Context specific-primitive-tag 2	10000010 ₂
	length = 1	00000001 ₂
	endPINX	00000000 ₂
	OMITTED	
END of NFE		
Network Prot Profile	OMITTED	
Interpretation APDU	OMITTED (default value = ROSE)	
Service APDU		
Invokeld	Context specific-constructed-invoke APDU	10100001 ₂
	Length = 35	00100011 ₂
LinkedId	Universal-integer tag 2	00000010 ₂
	length = 1	00000001 ₂
OperationValue	arbitrary value = 6	00000110 ₂
	OMITTED	
OperationValue	universal-object identifier tag 6	00000110 ₂
	length = 5	00000101 ₂
	encoding of { 0 4 0 392 0}	00000100 ₂
		00000000 ₂
		10000011 ₂
		00001000 ₂
		00000000 ₂
ARGUMENT		

Sequence	Universal constructed sequence	00110000 ₂
	Length = 23	00010111 ₂
SourceEntity	Context specific-primitive-tag 0	10000000 ₂
	length = 1	00000001 ₂
	ANF-ISIMM	00000010 ₂
DestinationEntity	Context specific-primitive-tag 1	10000001 ₂
	length = 1	00000001 ₂
	ANF-ISIMM	00000010 ₂
TETRA ISI MSG		

	Context specific-primitive-tag 2	10000010 ₂
	Length = 15	00001111 ₂
PDU Type	Migration	001101 ₂
ANF-ISIMM invoke id	arbitrary value: 1	0000000000000001 ₂
ISSI	arbitrary value: 010524 ₁₆	000000010101001000100 ₂
MNI (of ISSI)	arbitrary value: 000121 ₁₆	0000000000000000100100001 ₂
MNI (of visited SwMI)	arbitrary value: 000123 ₁₆	0000000000000000100100011 ₂
Migration type	migration	00 ₂
Restricted migration support	supported	0 ₂
Pre-defined profile set reference(s)	set no 1, 2 and 3 supported	1110000000000000 ₂
Group info	no grp info	0 ₂
Auth invocation	Authentication not invoked	0 ₂
Recovery	No recovery	0 ₂
Call rest. Supp.	Call restoration not supported	0 ₂
	padding	00 ₂

END of TETRA ISI MSG

Extension OMITTED

END of ARGUMENT**END of Service APDU****END of Information Element****END of QSIG FACILITY PDU**

Annex C (informative): Change requests

The present document includes change requests as presented in table C.1.

Table C.1: Change requests

No	CR vers.	Standard Version	Clauses affected	Title	CR Status
002	11	V1.2.1	2, 5.2, 5.4, 6.2.4, 6.3	ISI protocol stacks and stack usages	WG3 approved 081217
003	11	V1.2.1	2, 2.1, 2.2, 3.1, 5.2.1, 6.1.1.3, 6.1.1.4, 9.2	Editorial modifications	WG3 approved 090130
004	11	V1.2.1	5.2	ISI signalling LAPD	WG3 approved 090130
005	10	V1.2.1	6.3 (ex. 6.2.4)	Support of 8 kbit/s channels	WG3 approved 090130
006	10	V1.2.1	Annex	ASN.1 version XX \$\$	WG3 approved 091217
007	10	V1.3.1	8.3.2.2, 8.4.3, 8.4.4	Alignment of ISI General Design, ISI Mobility Management and ISI Short Data standards	WG3 approved 150511

History

Document history		
Edition 1	January 1999	Publication as ETSI ETS 300 392-3-1 (Historical)
V1.2.1	September 2002	Publication
V1.3.1	August 2010	Publication
V1.4.1	September 2015	EN Approval Procedure AP 20151206: 2015-09-07 to 2015-12-07
V1.4.1	December 2015	Publication